

i960[®] HA/HD/HT Superscalar Microprocessors



Product Overview

The i960[®] HA, i960 HD, and i960 HT processors provide solutions for designers needing to increase performance while containing their total embedded system cost. The i960 Hx processor series is the latest generation of the i960 architecture - the world's best selling RISC processor¹.

The three versions are differentiated by the relationship of the core clock speed to the external bus speed. The i960 HA processor core speed is equal to the external bus speed, the i960 HD processor core speed is double that of the external bus speed, and the i960 HT processor is triple that of the external bus speed.

The features of the processor have been selected with the assistance of customer input and simulation tools. The result is a processor that can execute up to three instructions per core clock and not be starved by a slow external system.

On-chip memory has been substantially increased, resulting in an increased hit-rate and reduced accesses to the external bus. The instruction cache for the i960 Hx processor series is 16 Kbytes, 4-way set associative. Critical code or interrupt routines may be locked into the cache for increased performance and decreased latency. The data cache is 8 Kbytes, 4-way set associative. Also on-chip is a 2 Kbyte data RAM which can be used for permanent storage of critical variables or interrupt vectors, further enhancing performance.

The i960 Hx processor series is object-code compatible with all i960 processor family members. This

enables quick migration of code, reduced time to market, and use of existing development tool knowledge.

Providing 150 MIPS, the i960 HT-75 MHz processor significantly increases the performance level previously available from the i960 architecture. Because the i960 HT processor runs at triple the external bus, the 75 MHz version connects to a low-cost 25 MHz external bus. This simplifies the design and lowers the total system cost.

Of course, not all embedded applications require such high performance. For that reason the product offering from the i960 Hx processors will start with the i960 HA 25 MHz processor, providing 50 MIPS. The series will meet several different price/performance points, adding to the product breadth of the i960 architecture. This increases the advantages for manufacturers to standardize around this popular family.

The i960 Hx processor series is 100% pin compatible and supported by several development tools, allowing for quick introduction of new products. The performance levels are the highest yet from a processor targeted at the embedded market. The on-chip features have been tuned for the embedded market, providing fast interrupt responses, reduced access to external memory, and integrated timers. To learn more about the i960 HA, HD, or HT processors, please contact your local sales representative or call 1-800-628-8686.

Processor	External Bus Speed (MHz)	Core Bus Speed (MHz)	Peak MIPS
i960 [®] HA processors	25, 33, 40	25, 33, 40	80
i960 [®] HT processors	25	75	150

¹Source: DataQuest 1993

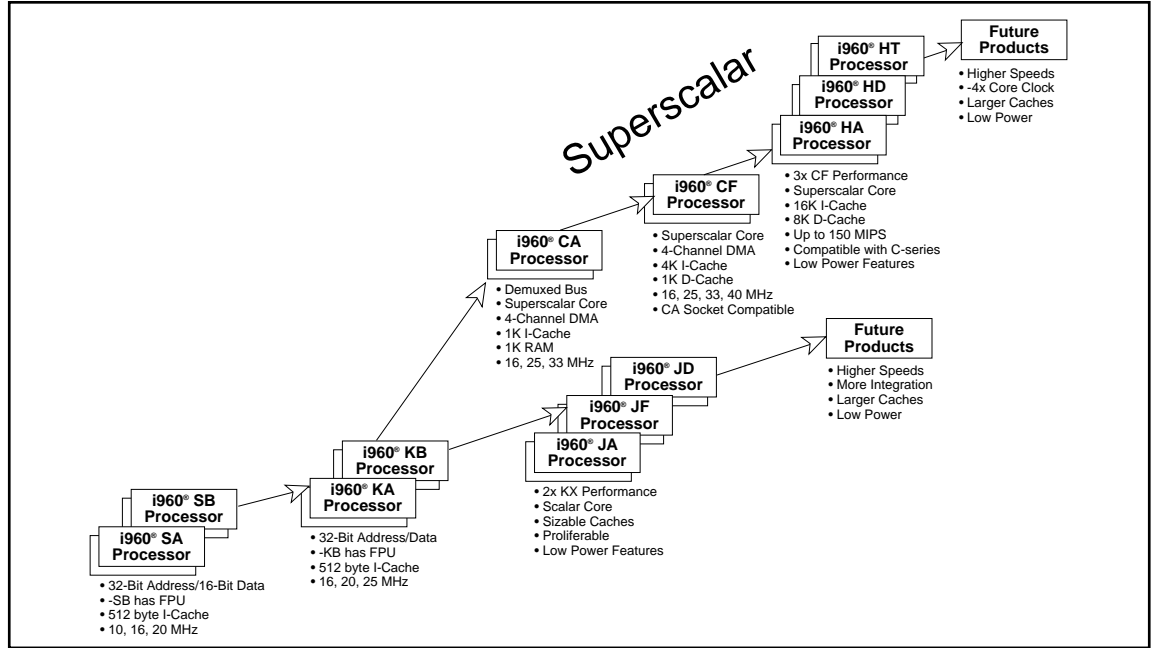

The i960[®] Hx processors offer a solid upgrade from the i960[®] Cx processors, at a low system cost.

Room to Grow: i960[®] Microprocessor Roadmap

Product Highlights

- Superscalar RISC core
- 16 Kbyte four-way set associative instruction cache
- 8 Kbyte four-way set associative data cache
- 2 Kbyte on-chip data RAM
- On-chip high-speed interrupt controller
- Processor runs at 1x, 2x, or 3x external clock speed
- Two 32-bit timers
- Parity generation and checking
- Guarded memory unit (GMU)
- Object-code compatible with i960 CA/CF processor family.
- 3.3 V supply, 5 V tolerant I/O
- Socket compatible with i960 CA/CF processors²

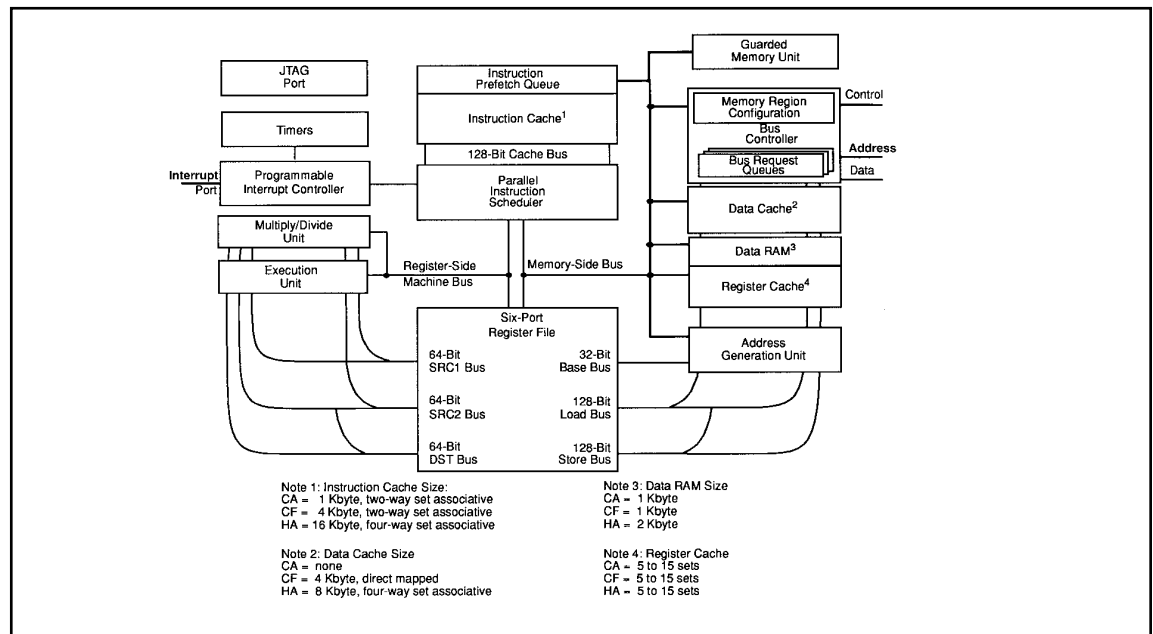

Intel's i960[®] Hx Microprocessor Block Diagram



Features

EASE OF DESIGN

- Object code-compatible with all members of i960® CA/CF processor family
- Excellent development tools from over 70 vendors
- One PGA socket may be designed to accept i960 Cx and Hx processor²
- Guarded Memory Unit
- 32-bit demultiplexed bus

PERFORMANCE

- 1.2 Gbyte/sec internal bandwidth (128 bits/cycle @ 75 MHz)
- Clock multiplied core
- Large instruction cache on-chip
 - 16 Kbyte four-way set associative
 - 128-bit path to instruction sequencer
 - Cache-lock, cache-off mode
- Large data cache on-chip
 - 8 Kbyte four-way set associate
 - 128 bits/clock on cache hit
- Superscalar
- Profiling compiler
- Unaligned accesses handled in hardware, not software
- New CISC instructions
- 3.3 volt, 0.6 micron process

INTEGRATION

- Two 32-bit timers
- Optional byte parity
- Wait state generator
- Interrupt controller
- JTAG - IEEE 1149.1 standard

Benefits

- Utilize existing knowledge and code
- Design with familiar tools
- Quick migration to higher performance with low design costs
- Code debug enhanced with protected segments
- Eliminates need for transceivers and latches
- Keep the processor fed with data and code from internal caches
- High performance processing with low-cost memory system
- Accelerates execution of standard software and time-critical interrupt routines
- Reduce external bus traffic, allowing for slower memory
- Provides 150 native MIPS at 75 MHz
- Reorganizes code for 30% performance improvement
- Reduced faults, increased useful code execution
- Reduce branches, code size by 10%
- Low power requirement
- High resolution event timing control
- All parity checking done on-chip
- Simplifies design for multiple memory types
- Provides prioritization of hardware and software interrupts with fast response times
- Enables debug and test of products

i960® Hx processors provide the highest performance yet to the embedded computing market.

² Requires board to be designed to specifications available from Intel.

i960® HA/i960 HD/i960 HT Microprocessor Application Areas

Office Automation

Page-printer controllers
Image scanners
X terminals
Local-area network (LAN) controllers and communications bridges (ATM, FDDI)
Database engines
Telecommunications and data communications equipment
I/O processing for workstations/servers

Industrial Robotics

Automated vision systems
Factory process control

Medical Instrumentation

Real-time data collection and analyses
Monitoring systems
Ultrasound imaging displays

Avionics and Aerospace

Flight-control equipment
Ground-to-air communication systems
Satellite navigation computers
Celestial telescope systems

Other

Arcade games
Theater controls

UNITED STATES
Intel Corporation
2200 Mission College
Boulevard
P.O. Box 58119
Santa Clara, CA 95052-8119

JAPAN
Intel Japan K.K.
5-6 Tokodai, Tsukuba-shi
Ibaraki, 300-26

FRANCE
Intel Corporation S.A.R.L.
1, Rue Edison, BP 303
78054 Saint-Quentin-en-
Yvelines Cedex

UNITED KINGDOM
Intel Corporation (U.K.) Ltd.
Pipers Way
Swindon
Wiltshire, England SN3 1RJ

GERMANY
Intel GmbH
Dornacher Strasse 1
8016 Feldkirchen bei Muenchen

HONG KONG
Intel Semiconductor Ltd.
32/F Two Pacific Place
88 Queensway
Central

CANADA
Intel Semiconductor of
Canada, Ltd.
190 Attwell Drive, Suite 500
Rexdale, Ontario M9W 6H8

Support Information

Product and Sales Information	Intel product information, sales office and distributor phone numbers	800-628-8686
Literature Department	To order Intel product literature.	800-548-4725
Development Tools Hotline	Technical applications support for Intel development tools.	800-843-4481
FaxBack Service	Automated response system that faxes Intel documents to your fax machine at no cost. For a listing of all i960 micro-processor documents, order FaxBack service document 2068.	800-628-2283
Applications Bulletin Board Service	24-hour access via modem to publicly available technical information. For a complete listing of all files available on BBS, call the FaxBack service and request catalog 6 (BBS Master File Listing).	916-356-3600

Phone numbers listed above are for U.S. and Canada only.

Intel Corporation assumes no responsibility for the use of any circuitry other than circuitry embodied in an Intel product. No other circuit patent licenses are implied. Information contained herein supersedes previously published specifications on these devices from Intel.

*Other brands and names are the property of their respective owners.

© Intel Corporation 1994

Order Number: 272590-001
Printed in the U.S.A./0994/15K/IL KG

 Printed on Recycled Paper

intel®