

E

AP-525

**APPLICATION
NOTE**

Pentium® Pro Processor Thermal Design Guidelines

September 1995

Order Number: 242766-001



Information in this document is provided solely to enable use of Intel products. Intel assumes no liability whatsoever, including infringement of any patent or copyright, for sale and use of Intel products except as provided in Intel's Terms and Conditions of Sale for such products.

Intel Corporation makes no warranty for the use of its products and assumes no responsibility for any errors which may appear in this document nor does it make a commitment to update the information contained herein.

Intel retains the right to make changes to these specifications at any time, without notice.

Contact your local Intel sales office or your distributor to obtain the latest specifications before placing your product order.

MDS is an ordering code only and is not used as a product name or trademark of Intel Corporation.

Intel Corporation and Intel's FASTPATH are not affiliated with Kinetics, a division of Excelan, Inc. or its FASTPATH trademark or products.

*Other brands and names are the property of their respective owners.

Additional copies of this document or other Intel literature may be obtained from:

Intel Corporation
Literature Sales
P.O. Box 7641
Mt. Prospect, IL 60056-7641
or call 1-800-879-4683

CONTENTS

	PAGE
1.0. INTRODUCTION	4
1.1. Document Goals	4
1.2. References.....	4
2.0. IMPORTANCE OF THERMAL MANAGEMENT	4
3.0. PENTIUM® PRO PROCESSOR PACKAGE SPECIFICATIONS.....	4
4.0. PENTIUM® PRO PROCESSOR POWER SPECIFICATIONS.....	4
5.0. THERMAL PARAMETERS	5
5.1. Case Temperature	5
5.2. Ambient Temperature	6
5.3. Thermal Resistance.....	7
5.3.1. ANALYSIS ASSUMPTIONS	8
6.0. DESIGNING FOR THERMAL PERFORMANCE.....	11
6.1. Airflow Management	12
6.2. Extruded Heat Sink Solutions	13
6.2.1. DESIGN EXAMPLE #1	13
6.2.2. DESIGN EXAMPLE #2	14
6.3. Fans 15	
6.3.1. DESIGN EXAMPLE #3	15
6.4. Alternative Cooling Solutions	16
6.4.1. DESIGN EXAMPLE #4	16
7.0. CONCLUSION	20

FIGURES

Figure 1. Location of Case Temperature Measurement (Top-Side View)	6
Figure 2. Thermocouple Placement	6
Figure 3. Thermal Resistance Relationships.....	8
Figure 4. Side View Of Omni-Directional Pin Fin Heat Sink.....	9
Figure 5. Θ_{CA} Versus Heat Sink Height	10
Figure 6. Power Dissipation Versus Heat Sink Height ($T_A=45^\circ\text{C}$).....	11
Figure 7. Simple Thermal Model.....	12
Figure 8. Example of Air Exchange Through a PC Chassis	13
Figure 9. Top View of Design Example #1	14
Figure 10. Top View of Design Example #2	15
Figure 11. Top View of Design Example #3	16
Figure 12. Top View of Design Example #4	17
Figure 13. Effective Flow Rate for Blower and Fan for the Ducted Cooling Scheme...18	
Figure 14. Case Temperature vs. Airflow at 30W19	
Figure 15. Case Temperature vs. Processor Power for Design Example #4	20

TABLES

Table 1. Case-to Ambient Thermal Resistance....	9
Table 2. Case-to Ambient Thermal Resistance..	10



1.0. INTRODUCTION

In a system environment, the processor's temperature is a function of both the system and component thermal characteristics. The system level thermal constraints include the local ambient temperature at the processor and the airflow over the processor(s), as well as the physical constraints at and above the processor(s). The processor's case temperature depends on the component's power dissipation and size, the effective thermal conductivity of the packaging material, the type of interconnection to the printed circuit board (PCB), the presence of a thermal cooling solution, and the thermal conductivity and power density of the PCB.

All of these parameters are aggravated by the continued push of technology to increase performance levels (higher operating speeds, MHz) and packaging density (more transistors). As operating frequencies increase and packaging size decreases, the power density increases and the thermal cooling solution space and airflow become more constrained. The result is an increased importance on system design to ensure that thermal design requirements are met for each component in the system.

1.1. Document Goals

The Pentium® Pro processor is the next generation in the Intel386™, Intel486™, and Pentium families of microprocessors. The Pentium Pro microprocessor generates sufficient heat to require some attention in order to meet the case temperature specification in system designs. The goal of this document is to provide an understanding of the thermal characteristics of the Pentium Pro processor, and to discuss guidelines for meeting the thermal requirements imposed on single and multiple processor systems.

In the future, Intel will provide an OverDrive® processor to upgrade single and dual Pentium Pro processor systems. The OverDrive processor will ship with an integrated fan/heat sink for thermal management. Guidelines for meeting the thermal specifications of the OverDrive processor are also included in this document.

1.2. References

The *Pentium® Pro Processor Developer's Manual, Volume 1* (Order Number 242690) is referenced throughout this document.

2.0. IMPORTANCE OF THERMAL MANAGEMENT

The objective of thermal management is to ensure that the temperature of all components in a system is maintained within functional and absolute maximum limits. The functional temperature limit is the range within which the electrical circuits can be expected to meet their specified performance requirements. Operation outside the functional limit can degrade system performance, or cause logic errors, component and/or system damage. The absolute maximum temperature limit is the highest temperature to which the component may be safely exposed. Temperatures exceeding the maximum operating limits may result in irreversible changes in the operating characteristics of the component.

3.0. PENTIUM® PRO PROCESSOR PACKAGE SPECIFICATIONS

The Pentium Pro processor is packaged in a 2.46" x 2.66", 387 pin ceramic pin grid array (PGA) with a gold plated copper tungsten heat spreader. The pins are arranged in a modified staggered array. Please see the *Pentium® Pro Processor Developer's Manual, Volume 1* for complete dimensions.

4.0. PENTIUM® PRO PROCESSOR POWER SPECIFICATIONS

The Pentium Pro processor power dissipation can be found in the *Pentium® Pro Processor Developer's Manual, Volume 1*. It is highly recommended that systems be designed to dissipate 40W per processor, as this will allow the same design to accommodate higher frequency or otherwise enhanced members of the Pentium Pro family.

To ensure proper operation and reliability of the Pentium Pro processor, the maximum device case temperature must remain within the specification in the *Pentium® Pro Processor Developer's Manual, Volume 1*. A typical case temperature is 85°C. Considering the power dissipation levels and typical ambient environments of 35°C to 45°C, the Pentium Pro processor's specified case temperature cannot be maintained without additional thermal enhancement to dissipate the heat generated. The OverDrive processor for upgrading Pentium Pro processor systems will be equipped with an integrated fan/heat sink, and will remain within its specified temperature limits provided the fan/heat sink air inlet temperature does not exceed



the specified temperature in the *Pentium® Pro Processor Developer's Manual, Volume 1*. This air temperature is typically 50°C.

The thermal characterization data described in later sections illustrates that both a thermal cooling device and system airflow are needed. The size and type (passive or active) of thermal cooling device and the amount of system airflow are interrelated and can be varied to meet specific system design constraints. In typical systems, the thermal solution size and type is limited by board layout, spacing, and component placement. Airflow is determined by the size and number of fans along with their placement in relation to the components and the airflow channels within the system. Acoustic noise constraints may also limit the size and/or types of fans that can be used in a particular design.

To develop a reliable, cost-effective thermal solution, all of the above variables must be considered. Thermal characterization and simulation should be carried out at the entire system level, accounting for the thermal requirements of each component.

5.0. THERMAL PARAMETERS

Component power dissipation results in a rise in temperature relative to the temperature of a reference point. The amount of rise in temperature depends on the net thermal resistance between the component's package and the reference point. Thermal resistance is the key factor in determining the power handling capability of any electronic package.

5.1. Case Temperature

To ensure functionality and reliability, the Pentium Pro processor is specified for proper operation when case temperature (T_C) is within a specified range: typically 0°C to 85°C. Special care is required when measuring the case temperature to ensure an accurate temperature measurement. Thermocouples are often used to measure T_C . When measuring the temperature of a surface which is at a different temperature from the surrounding ambient air, errors could easily be introduced into the measurements. Measurement errors may occur due to a poor thermal contact between the thermocouple junction and the surface, or heat loss by radiation or conduction through the thermocouple leads. To minimize the measurement errors, the following approach is recommended:

- Use a 35 gauge K-type thermocouple or equivalent.
- Ensure that the thermocouple has been properly calibrated.
- Attach the thermocouple bead or junction to the package top surface at a location corresponding to the center of the Pentium Pro processor die (location \textcircled{A} in Figure 1). Using the center of the Pentium Pro processor die gives a more accurate measurement and less variation as the boundary condition changes.
- Attach the thermocouple bead or junction at a 90° angle by an adhesive bond to the package top surface as shown in Figure 2. When a heat sink is attached, a hole should be drilled through the heat sink to allow a probe to reach the package directly above the center of the Pentium Pro processor die. The hole diameter should be no larger than 0.150".

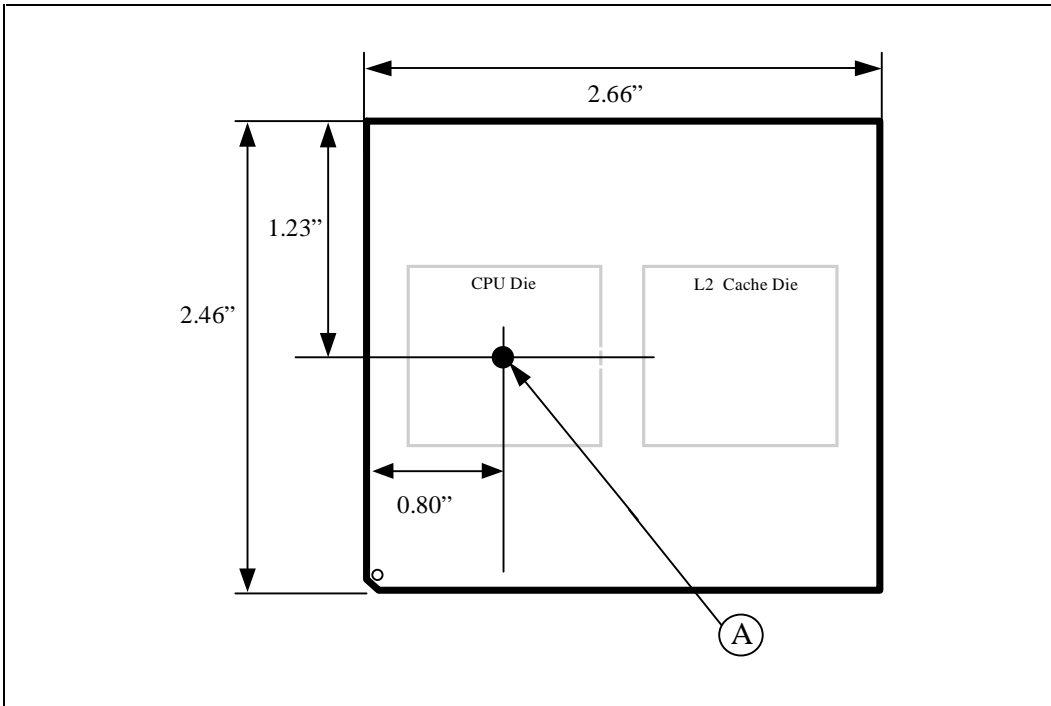

Figure 1. Location of Case Temperature Measurement (Top-Side View)

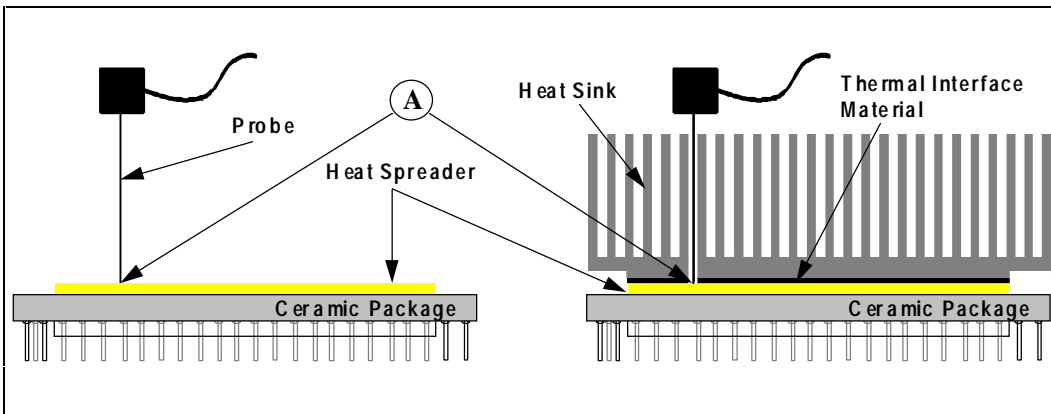

Figure 2. Thermocouple Placement



5.2. Ambient Temperature

Ambient temperature (T_A) is the temperature of the ambient air surrounding the package. In a system environment, ambient temperature is the temperature of the air upstream of the package and in its close vicinity. If an active cooling solution is used, T_A is the temperature at the inlet to the active cooling device.

The OverDrive processor for upgrading Pentium Pro processor-based systems specifies a T_A for its integrated fan/heat sink assembly. However, an ambient temperature is not directly specified for the Pentium Pro processor. The only restriction is that case temperature (T_C) is met. To determine the allowable T_A values, the following equations may be used:

$$T_C = T_A + (P_D * \Theta_{CA})$$

Where: T_A = Ambient temperature (°C)
 T_C = Case temperature of the device (°C)
 P_D = Total power dissipated by the dies (W)
 Θ_{CA} = Case-to-ambient thermal resist. (°C/W)

5.3. Thermal Resistance

The case-to-ambient thermal resistance value (Θ_{CA}) is used as a measure of the cooling solution's thermal

performance. Θ_{CA} is comprised of the case-to-sink thermal resistance (Θ_{CS}) and the sink-to-ambient thermal resistance (Θ_{SA}). Θ_{CS} is a measure of the thermal resistance along the heat flow path from the top of the IC package to the bottom of the thermal cooling solution. This value is strongly dependent on the material, conductivity, and thickness of the thermal interface used. Θ_{SA} is a measure of the thermal resistance from the bottom of the heat sink to the local ambient air. Θ_{SA} values depend on the material, thermal conductivity, and geometry of the thermal cooling solution as well as on the airflow rates.

The parameters are defined by the following relationships (see Figure 3):

$$\Theta_{CA} = (T_C - T_A) / P_D$$

$$\Theta_{CA} = \Theta_{CS} + \Theta_{SA}$$

Where: Θ_{CA} = Case-to-ambient thermal resist. (°C/W)
 Θ_{CS} = Case-to-sink thermal resistance (°C/W)
 Θ_{SA} = Sink-to-ambient thermal resist. (°C/W)
 T_C = Case temperature of the device (°C)
 T_A = Ambient temperature (°C)
 P_D = Total power dissipated by dies (W)

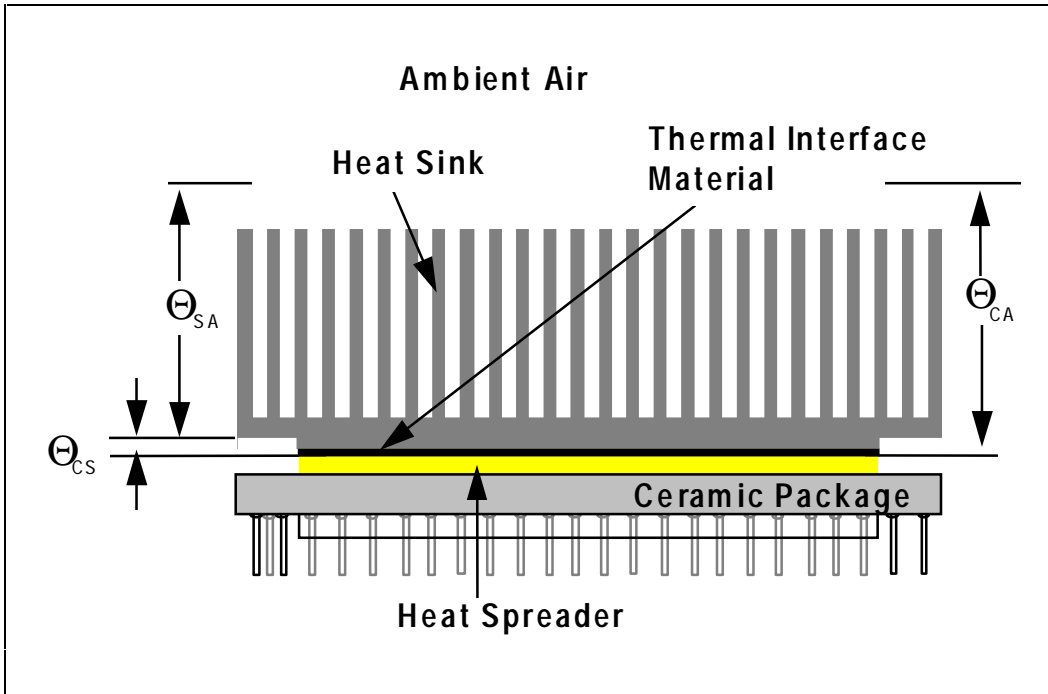

Figure 3. Thermal Resistance Relationships

5.3.1. ANALYSIS ASSUMPTIONS

The following example thermal analysis of a Pentium Pro processor package is based on the following assumptions:

- Power dissipation of the Pentium Pro processor die is 24W
- Power dissipation of the L2 cache die is 4W
- Maximum case temperature is 85°C

The actual specifications can be found in the *Pentium® Pro Processor Developer's Manual, Volume 1*. Table 1 below lists the Pentium Pro processor's case-to-ambient thermal resistance for different airflow rates and heat sink heights. Table 2 translates this to the ambient temperature required for different airflow rates and heat sink heights. This information is also charted in Figure 5. In addition, Figure 6 charts power dissipation versus heat sink height.

Table 1. Case-to Ambient Thermal Resistance

	Θ_{CA} [$^{\circ}\text{C}/\text{W}$] vs. Airflow [Linear Feet per Minute] and Heat Sink Height ¹					
Airflow (LFM):	100	200	400	600	800	1000
With 0.5" Heat sink ²	----	3.16	2.04	1.66	1.41	1.29
With 1.0" Heat sink ²	2.55	1.66	1.08	0.94	0.80	0.76
With 1.5" Heat sink ²	1.66	1.31	0.90	0.78	0.71	0.67
With 2.0" Heat sink ²	1.47	1.23	0.87	0.75	0.69	0.65

NOTES:

1. All data taken at sea level. For altitudes above sea level, it is recommended that a derating factor of $1^{\circ}\text{C}/1000$ feet be used.
2. Heat sink: 2.235" square omni-directional pin, aluminum heat sink with a pin thickness of 0.085", a pin spacing of 0.13" and a base thickness of 0.15". See Figure 4. A thin layer of thermal grease (Thermoset TC208 with thermal conductivity of 1.2 $\text{W}/\text{m}^{\circ}\text{K}$) was used as the interface material between the heat sink and the package.

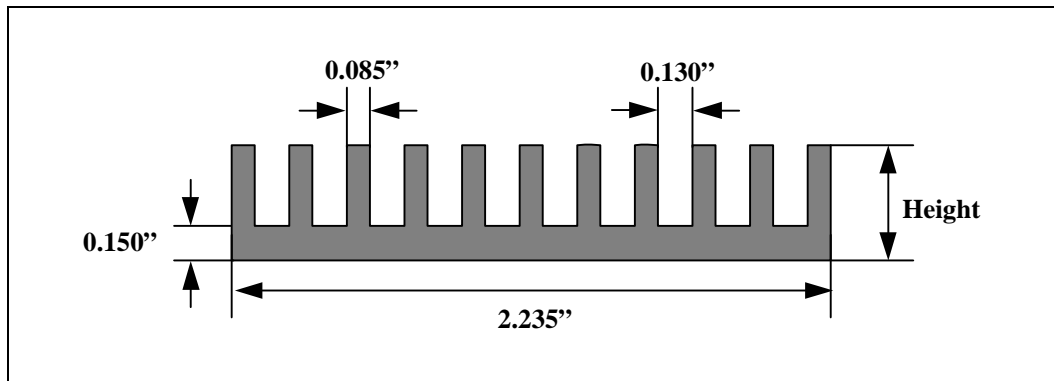

Figure 4. Side View Of Omni-Directional Pin Fin Heat Sink

Table 2. Case-to Ambient Thermal Resistance

	T_A vs. Airflow [Linear Feet per Minute] and Heat Sink Height¹					
Airflow (LFM):	100	200	400	600	800	1000
With 0.5" Heat sink ²	----	-4	27	38	45	48
With 1.0" Heat sink ²	13	38	54	58	62	63
With 1.5" Heat sink ²	38	48	59	63	65	66
With 2.0" Heat sink ²	43	50	60	64	65	66

NOTES:

1. All data taken at sea level. For altitudes above sea level, it is recommended that a derating factor of 1°C/1000 feet be used.
2. Heat sink: 2.235" square omni-directional pin, aluminum heat sink with a pin thickness of 0.085", a pin spacing of 0.13" and a base thickness of 0.15". See Figure 4. A thin layer of thermal grease (Thermoset TC208 with thermal conductivity of 1.2 W/m²K) was used as the interface material between the heat sink and the package.

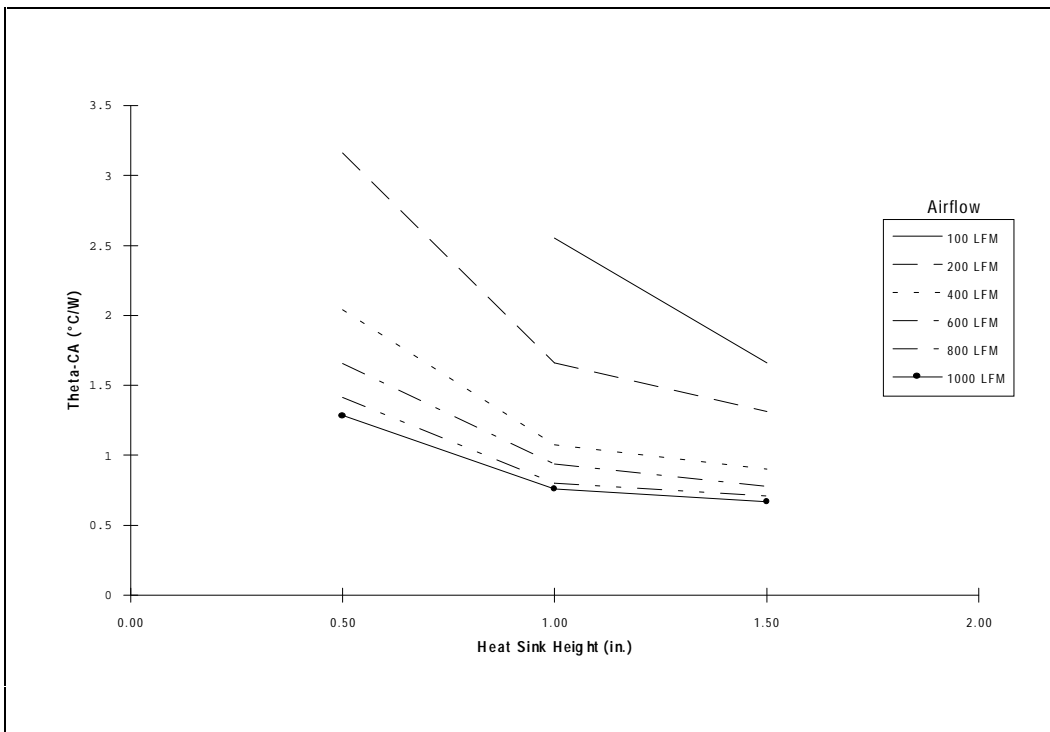

Figure 5. θ_{CA} Versus Heat Sink Height



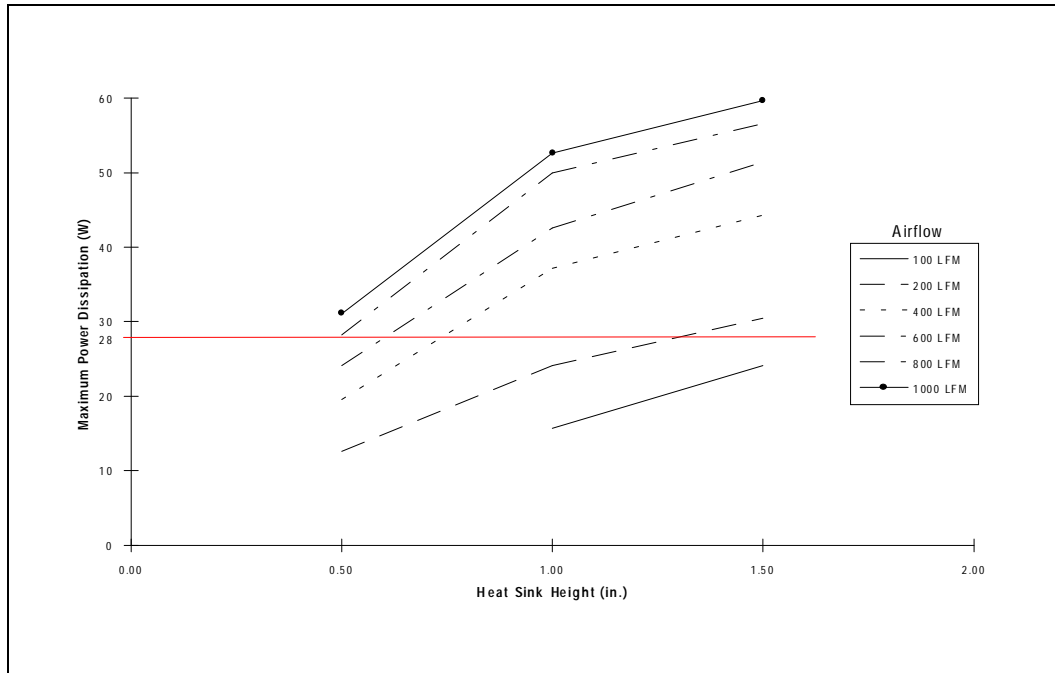

Figure 6. Power Dissipation Versus Heat Sink Height (T_A=45°C)

6.0. DESIGNING FOR THERMAL PERFORMANCE

The Pentium Pro processor specifies a maximum case temperature, T_C. This case temperature limit, along with external ambient temperature and the Pentium Pro processor's power specification, can be used to determine the case-to-ambient thermal resistance of the cooling

solution required to keep the Pentium Pro processor within its operational limits.

Figure 7 shows a simple model for use in calculating various thermal parameters based on known values. This model can theoretically be extended to any number of processors.



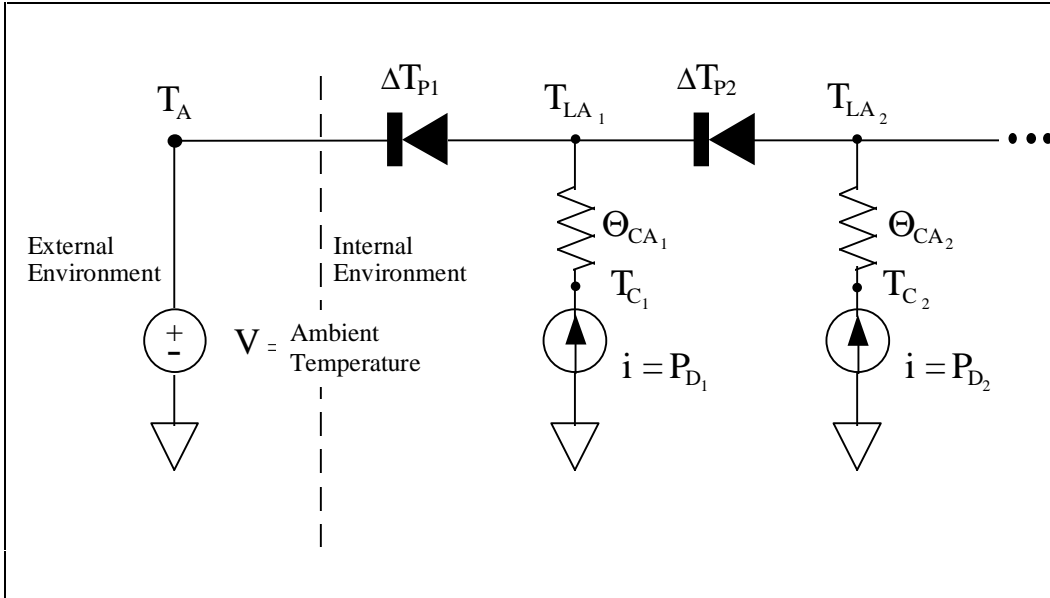

Figure 7. Simple Thermal Model

The equations governing this simple model are:

$$T_{C1} = T_A + \Delta T_{P1} + (P_{D1} * \Theta_{CA1})$$

$$T_{C2} = T_A + \Delta T_{P1} + \Delta T_{P2} + (P_{D2} * \Theta_{CA2})$$

- where: T_A = External ambient temperature (°C)
 T_{LA} = Local ambient temperature (°C)
 T_C = Case temperature of the device (°C)
 P_D = Power dissipated by the device under test
 Θ_{CA} = Case-to-ambient thermal resist. (°C/W)
 ΔT_P = Temperature rise between elements

6.1. Airflow Management

To maximize the amount of air that flows over the processor and minimize the local ambient temperature (T_{LA}) near the processor, it is important to manage the amount of air that flows within the system as well as how it flows. Total system air flow can be increased by adding one or more fans to the system, or by increasing the output of an existing system's fan(s). An important consideration in airflow management is the temperature of the air flowing over the processor(s). Heating effects

from add-in boards, DRAM, and disk drives greatly reduce the cooling efficiency of this air, as does recirculation of warm interior air through the system fan. Care must be taken to minimize the heating effects of peripheral components, and to eliminate warm air recirculation.

For example, a clear air path from the external system vents to the system fan(s) will enable the warm air from the Pentium Pro processors to be efficiently pulled out of the system. If no air path exists across the processors, the warm air from the Pentium Pro processors will not be removed from the system, resulting in localized heating ("hot spots") around the processors. Figure 8 shows two examples of air exchange through a PC style chassis. The system on the left is an example of good air exchange, incorporating both the power supply fan, and an additional system fan. The system on the right shows a poorly vented system, using only the power supply fan to move the air, resulting in inadequate air flow. Recirculation of warm air is most common between the system fan and chassis, and between the system fan intake and the drive bays behind the front bezel. These paths may be eliminated by mounting the fan flush to the chassis, obstructing the flow between the drive bays and fan inlet, and by providing generous intake vents in both the chassis and the front bezel.



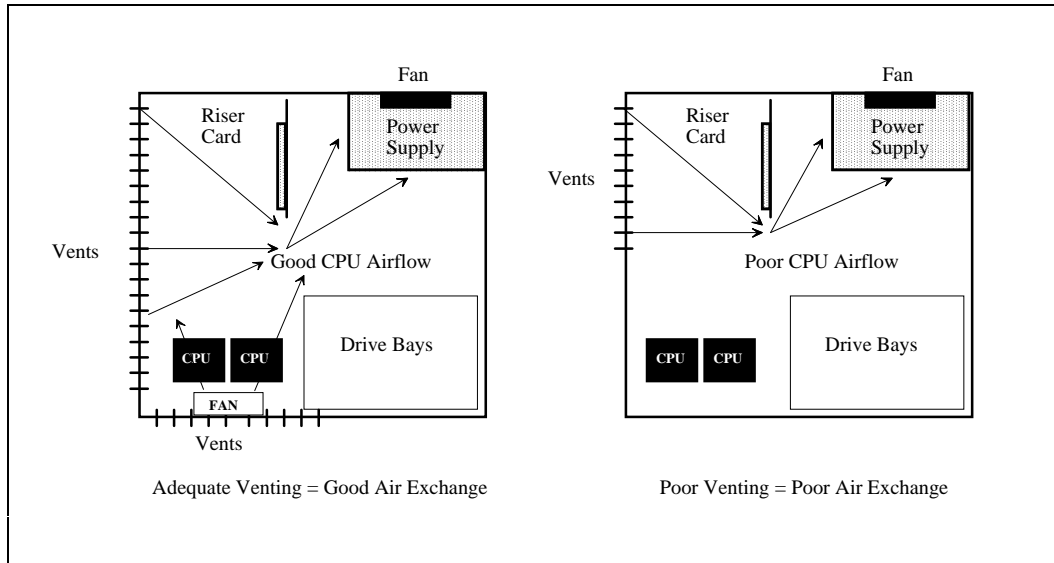

Figure 8. Example of Air Exchange Through a PC Chassis

6.2. Extruded Heat Sink Solutions

One method used to improve case-to-ambient thermal performance is to increase the surface area of the device, by attaching a metallic heat sink to the ceramic package. Heat sinks are generally extruded from blocks of metal, usually aluminum (due to its low price/performance ratio). To maximize the thermal conduction, the thermal resistance from the heat sink to the air can be reduced by maximizing the airflow through the heat sink fins as well as by maximizing the surface area of the heat sink itself.

6.2.1. DESIGN EXAMPLE #1

In Example #1, two Pentium Pro processors are placed side-by-side in front of a dedicated 80mm fan. The fan pulls air from outside the system chassis and pushes the air over the processors, providing approximately 200 LFM of laminar airflow over the processors, as shown in Figure 9. Using the simple thermal model in Figure 7 and assuming a maximum external ambient temperature of

45°C, a maximum case temperature of 85°C, a maximum power dissipation of 28 Watts, and a local processor ambient of 50°C, the following equation can be used to calculate the Θ_{CA} required for either of the two processors in this particular system:

$$\Theta_{CA} = (T_C - T_{LA})/P_D$$

Where: $T_{LA} = T_A + \Delta T_p$

Solving the equation shows that the case-to-ambient thermal resistance required in this particular Pentium Pro processor system is 1.25°C/W. Using Table 1, it can be seen that a 1.0" heat sink with an airflow between 200 and 400 LFM will meet the Pentium Pro processor maximum case temperature limit of 85°C. Linearly extrapolating the values in Table 1 gives an airflow of approximately 340 LFM. To keep the airflow within the 200 LFM assumption, a heat sink approximately 1.9" in height would be required.



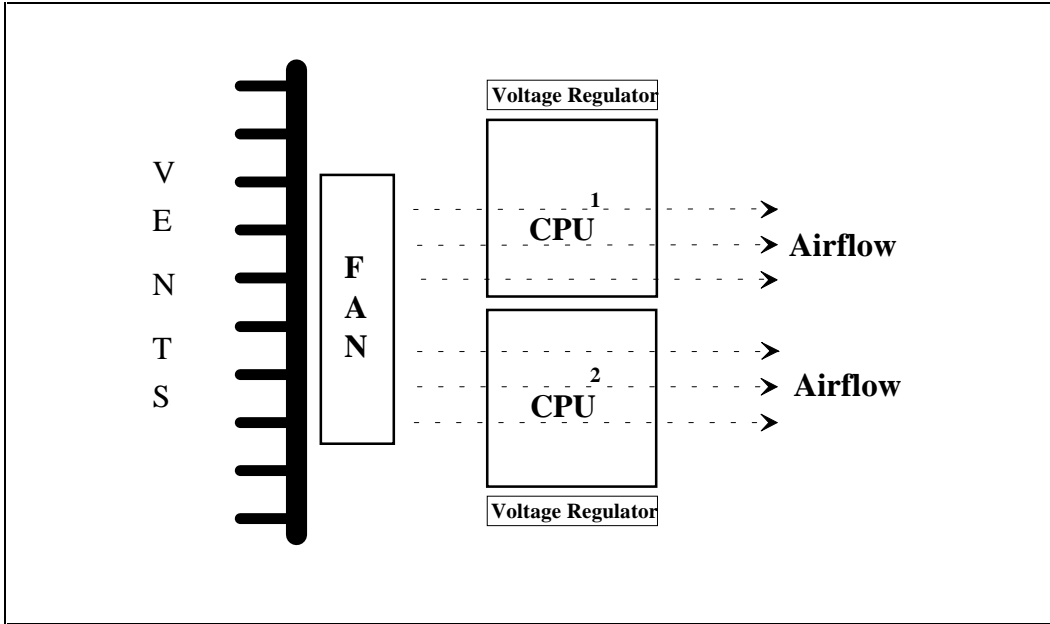

Figure 9. Top View of Design Example #1

6.2.2. DESIGN EXAMPLE #2

In Example #2, the processors are placed in a row directly in front of the system fan. There is a dedicated 80 mm fan directly in front of the first processor providing approximately 600 LFM of laminar airflow (see Figure 10). Using the simple thermal model in Figure 7 and assuming a maximum external ambient temperature of 45°C, a maximum case temperature of 85°C, a maximum power dissipation of 28 Watts, and a local processor ambient of 50°C, the following equation can be used to calculate the Θ_{CA_1} required to cool the first processor in this system:

$$\Theta_{CA_1} = (T_{C_1} - T_{LA_1})/P_{D_1}$$

Where: $T_{LA_1} = T_A + \Delta T_{P_1}$

Solving the equation shows that the case-to-ambient thermal resistance required to cool the first Pentium Pro processor in this system is 1.25°C/W. Referring to Table 1, it can be seen that with 600 LFM, a heat sink between 0.5" and 1.0" meets the Pentium Pro maximum case temperature limit of 85°C. Linearly extrapolating the

values in Table 1 gives an a heat sink height of approximately 0.87".

Heat from the first processor will elevate the air temperature over the second processor. For the purpose of this example, it will be assumed that the temperature elevation due to the first processor is 15°C, resulting in an air temperature of 60°C at the second processor (the exact temperature rise due to the first processor is system dependent. Individual designs must be characterized to determine the temperature rise at the second processor).

In addition, the first Pentium Pro processor will disrupt and block the airflow from the dedicated fan, affecting the air reaching the second processor. Individual system designs must be characterized to understand the airflow over the second processor. Also, since the airflow is not necessarily laminar airflow, the values in Table 1 may not be accurate. For the purpose of this example, a 400 LFM airflow over the second processor will be assumed. Using the simple electrical model in Figure 7, the following equation can be used to calculate the Θ_{CA_2} required to cool the second processor in this system:



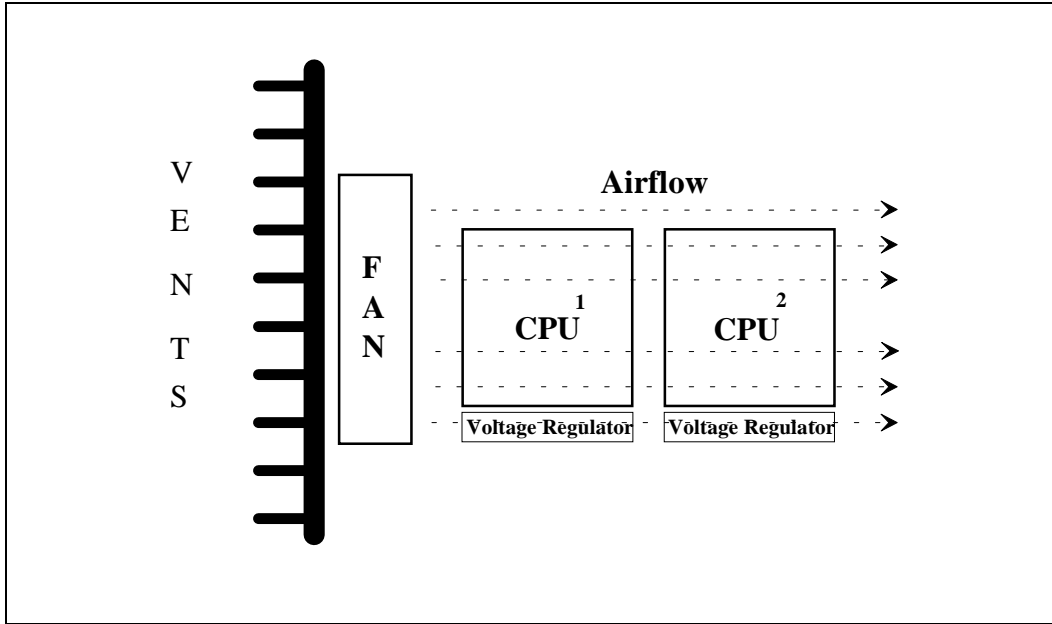

Figure 10. Top View of Design Example #2

$$T_{C_2} = T_{LA_1} + \Delta T_{P_2} + (P_{D_2} * \Theta_{CA_2})$$

Where: T_p = Air temperature at the device under test
 $85^\circ\text{C} = 60^\circ\text{C} + (28 \text{ Watts} * \Theta_{CA_2})$
 $\Theta_{CA_2} = 0.89^\circ\text{C/Watt}$

Using $\Theta_{CA} = 0.89^\circ\text{C/Watt}$ and Table 1, it can be seen that a 1.5" heat sink with an airflow of 400 LFM will meet the Pentium Pro processor maximum case temperature limit of 85°C .

6.3. Fans

Fans are often needed to assist in moving the air inside a chassis. The airflow rate of a fan is usually directly related to the acoustic noise level of the fan and system. Maximum acceptable noise levels may limit the fan output or the number of fans selected for a system.

Fan/heat sink assemblies are one type of advanced solution which can be used to cool the Pentium Pro microprocessor. The OverDrive processor for upgrading Pentium Pro processor-based systems will use an integrated fan/heat sink. Intel has worked with fan/heat sink vendors and computer manufacturers to make fan/heat sink cooling solutions available in the industry for use with the Pentium Pro processor in systems. Please

consult such a vendor to acquire the proper solution for your needs.

6.3.1. DESIGN EXAMPLE #3

Example #3 shows a single Pentium Pro processor cooled with a fan/heat sink assembly (see Figure 11). The simple thermal model in Figure 7 can be used to calculate the required Θ_{CA} to cool a 28 Watt Pentium Pro processor. Assuming a maximum external ambient temperature of 45°C , a maximum case temperature of 85°C , and a temperature rise from the external ambient to the Pentium Pro processor of 5°C , the following equation can be used:

$$\Theta_{CA_1} = (T_{C_1} - T_{LA_1})/P_{D_1}$$

Where: $T_{LA_1} = T_A + \Delta T_{P_1}$

Solving the equation shows that the fan/heat sink assembly must be able to produce a case-to-ambient thermal resistance of 1.25°C/W to cool the Pentium Pro processor in this system. This calculation can be extended to include multiple Pentium Pro processors in a system.

Note that the OverDrive processor is designed to meet its thermal requirements if the fan/heat sink inlet air temperature is 50°C or less.

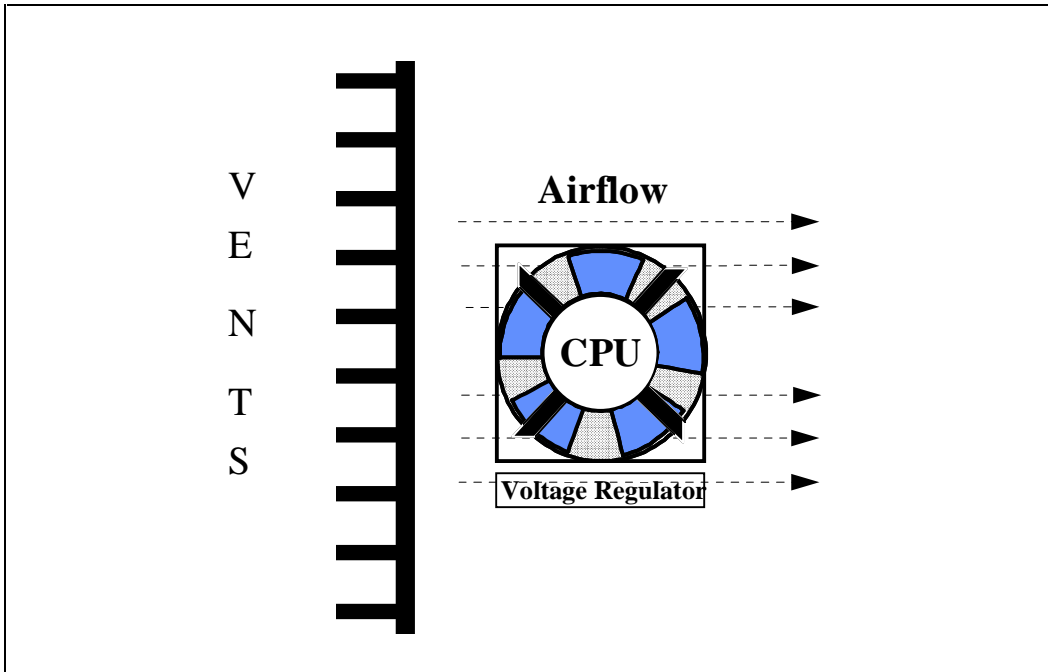

Figure 11. Top View of Design Example #3

6.4. Alternative Cooling Solutions

In addition to extruded heat sinks and system fans, other solutions exist for cooling integrated circuit devices. For example, ducted blowers, heat pipes and liquid cooling are all capable of dissipating additional heat. Due to their varying attributes, each of these solutions may be appropriate for a particular system implementation.

6.4.1. DESIGN EXAMPLE #4

The Pentium Pro processor is designed to provide scaleable performance in a multiprocessor system; up to four processors can be used in such a configuration. In order to minimize interconnect delays between the processors in an MP environment, the processors must be connected in close proximity. Example #4 demonstrates the use of low cost, high density, extruded heat sinks enclosed in a duct to provide the thermal headroom necessary to cool four Pentium Pro processors while maintaining case temperatures of 85°C. Note that since the OverDrive processor will upgrade single or dual processor Pentium Pro processor-based systems, cooling solution compatibility with the OverDrive processor need only be considered for those system configurations.

6.4.1.1. AIRFLOW CHARACTERIZATION

In this example, two Pentium Pro processors are placed side by side upstream, and two side by side downstream to make a quad processor unit. Each processor's power is locally supplied by a DC/DC converter (see Figure 12). Extruded fin heat sinks with a high aspect ratio (i.e. 12:1 fin height to gap width), 1.2" tall, and with dimensions defined by the plan area of the CPU package are mounted on each of the Pentium Pro processors. The outline of the duct is designed to ensure that the air from the blower is directed through the heat sinks. Air is purged from the system via vents located behind the downstream processors. A single 120 mm blower, mounted in front of the CPU module, provides the airflow through the assembly. For this example, it is recommended that the intake and outlet vents in the chassis be at least 50 percent open.

Assuming a cooling target of 40 Watts per processor (with the processors as the maximum heat-generating parts in the assembly), this duct was designed to isolate the processors from the effects of system heating (such as from add-in cards), and to maximize the processor

cooling temperature budget. Air provided by the blower is split into two parallel paths to cool the processors. A one dimensional model based on drag and frictional losses was developed, using airflow resistance elements to evaluate the operating points of various air moving devices. Although the duct is not symmetrical, assuming equal amounts of airflow through the two parallel paths provides a reasonable approximation of the operating point (the actual airflow delivered by a device attached to the duct in a system environment). Fan and blower manufacturers provide performance curves, characterized by the amount of airflow that the device can deliver at different resistances to the flow (represented by static pressure). At maximum static pressure, the amount of airflow delivered is usually zero, and airflow (measured in cubic feet per minute, or CFM) at no static pressure is the maximum theoretically achievable. The practically realizable airflow through the ducted environment is dependent on the heat sinks' resistance to airflow. The amount of airflow delivered by a fan or blower is the intersection point between the performance curve of the device (provided by the device's manufacturer) and the system resistance curve, which is calculated by the friction and drag contributions of the various resistance elements in the flow path. Energy is spent to move air through bends, expansions,

and contractions (which contribute to drag), and friction from surfaces of duct walls and heat sink fins. Shown in Figure 13 are the resistance characteristics for a single air moving device in conjunction with a single high density extruded heat sink (60 mil thick fins, 90 mil fin gap). Maximizing friction and minimizing the drag contribution is desirable.

For comparison purposes, a typical 120mm system fan is also plotted. Axial fans are typically characterized by a high volumetric flow rate, but low pressure drop in the system. In contrast, a blower has a significantly higher pressure drop characteristic, with a lower flow rate, for identical dimensions. The system resistance curve (friction and drag contributions for the ducted cooling scheme) has a significant slope. The fan shown in this example is typically rated at 100 CFM, and the blower is rated at 25 CFM. In the absence of the analysis above, it is common to assume that a system fan provides significantly higher airflow, which translates to improved cooling; however, the effective airflow rate delivered by the 100 CFM fan is about 8 CFM, while the blower provides twice this effective flow rate. This translates to 14 CFM, or 7 CFM through each of the two parallel paths within the duct.

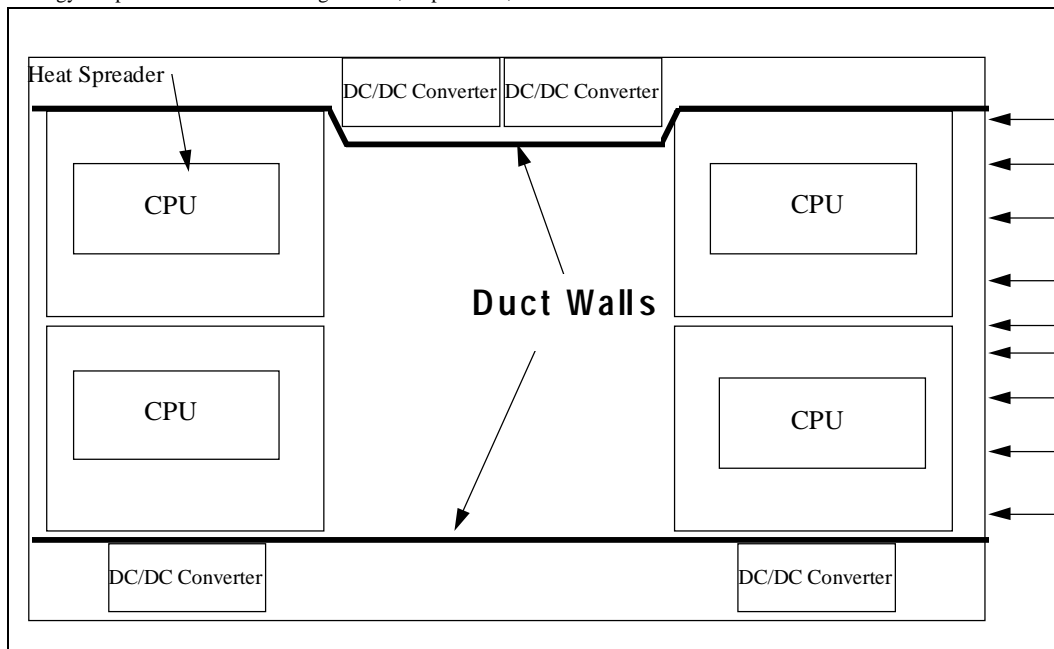

Figure 12. Top View of Design Example #4



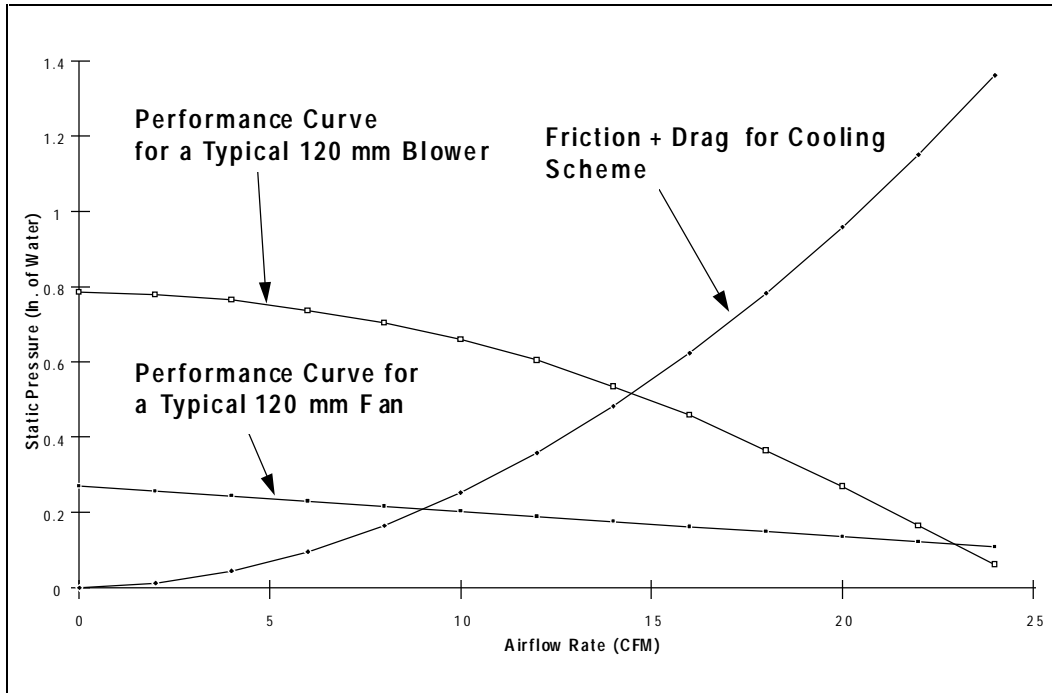

Figure 13. Effective Flow Rate for Blower and Fan for the Ducted Cooling Scheme

6.4.1.2. THERMAL PERFORMANCE CHARACTERIZATION

The physical constraints of this layout require that at least one Pentium Pro processor be placed downstream of the other. In addition, all the air entering the duct must pass through both the upstream and downstream heat sinks. The power dissipation capability of this cooling scheme can be assessed using flat plate heat transfer correlation.

Figure 14 shows temperature predictions at different air flow rates through the heat sinks, assuming a power dissipation of 30 Watts per Pentium Pro processor. The overall flow rate from the blower, based on the performance curves above, is assumed to be split equally between two parallel paths on the module. Since the upstream and downstream heat sinks are at the opposite ends of the module, it is reasonable to expect the air entering the downstream heat sinks has an average mixed temperature, which will be higher than the ambient temperature of the upstream heat sinks. This difference is particularly significant at low flow rates. Figure 15 shows the case temperature values plotted against different air

flow rates through the high density heat sinks, using this one dimensional model, at sea level. As the airflow rate increases, more air is available to purge the warm air from the system, reducing the temperature of the system. 1 CFM of airflow through the heat sinks roughly corresponds to 100 LFM of airflow, and 25 CFM to 2,300 LFM. To produce such flow rates in an open air test environment such as a wind tunnel or unducted flow, a minimum of 2 to 3 times the airflow around the heat sink is required. Observe that the temperature drops off rapidly with increasing flow rate, reaching an asymptotic value. This suggests that higher airflow for a given heat sink will not necessarily translate to significant gains in the reduction of case temperature. These calculations, along with the airflow performance curves, demonstrate that it is not fundamentally beneficial to increase airflow. Increasing airflow results in an increase in the pressure drop requirement, translating to large, noisy blowers which are not conducive to an office environment. Based on an operating point of 14 CFM for a single blower (i.e. 7 CFM through each parallel flow path), the calculated temperatures for the upstream and downstream Pentium Pro processors in this cooling arrangement are 53°C and 61°C at a 35°C ambient. Clearly both the upstream and downstream processors have significant thermal



headroom. The extent of the upstream processor's heat on the air which reaches the downstream processor is kept at a minimum due to the mixing and high airflow rates achieved in the blower cooling arrangement. Also note that an arrangement which uses a 120 mm fan with a duct cannot maintain the case temperature of the downstream processor below the recommended temperature of 85°C, and hence is not recommended as a cooling option for a quad processor arrangement.

Figure 15 shows the power versus case temperature tradeoff for this ducted blower approach. The conventional approach of using a system fan with low aspect ratio heat sinks that are typical in the industry is also included for comparison. The classical approach of widely spaced fins results in a heat sink which is ineffective in cooling high performance systems with processors in close proximity. This blower solution, however, can provide scalability to 40 Watts without any changes in the design.

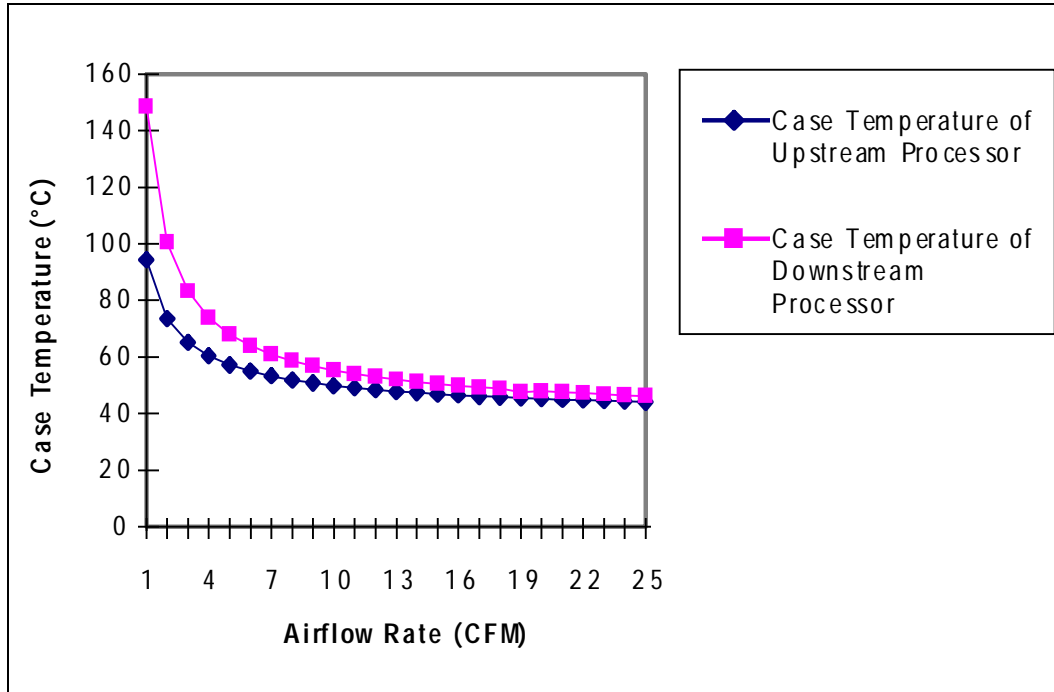

Figure 14. Case Temperature vs. Airflow at 30W



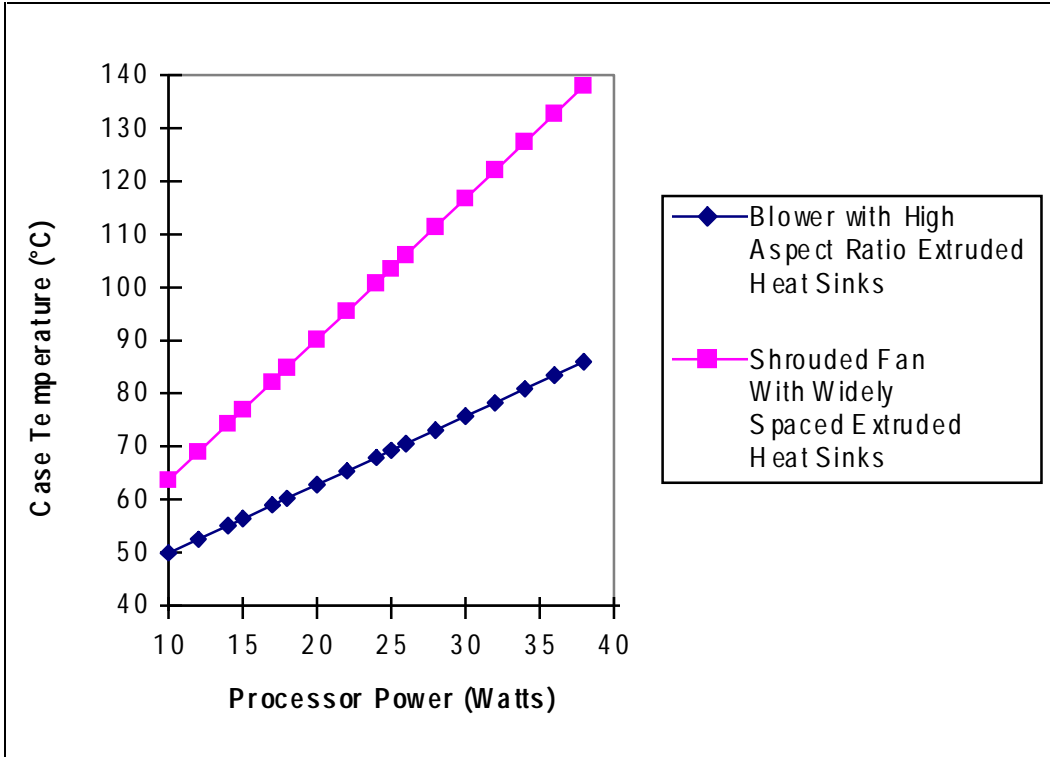

Figure 15. Case Temperature vs. Processor Power for Design Example #4

7.0. CONCLUSION

As the complexity of today's microprocessors continues to increase, so do the power dissipation requirements. Care must be taken to ensure that the additional power is properly dissipated. Heat can be dissipated using passive heat sinks, fans and/or active cooling devices. Further cooling can be achieved through the use of ducting solutions.

The simplest and most cost effective method is to use an extruded heat sink and a system fan. The size of the heat sink and the output of the fan can be varied to balance size and space constraints with acoustic noise. As shown, a 1.9" high heat sink can be used with a dedicated 200 LFM system fan to cool a Pentium Pro processor dissipating 28 Watts. In another example, it was shown

that a fan/heat sink assembly having a Θ_{CA} of 1.25°C/W can also be used to cool a single Pentium Pro processor dissipating 28 Watts, as long as the local ambient temperature does not exceed 50°C. This will also be the requirement for the OverDrive processor for upgrading Pentium Pro processor-based systems.

Both of these solutions provide adequate cooling to maintain the Pentium Pro processor's case temperature at or below 85°C. The addition of ducting allows cooling of up to four Pentium Pro processors. By maintaining the Pentium Pro processor's case temperature and OverDrive processor's fan/heat sink air inlet temperature at the values specified in the *Pentium® Pro Processor Developer's Manual, Volume 1*, a system can guarantee proper functionality and reliability of these processors.

