



**AP-479**

**APPLICATION  
NOTE**

**Pentium®  
Processor  
Clock Design**

November 1995



Order Number: 241574-002

Information in this document is provided in connection with Intel products. Intel assumes no liability whatsoever, including infringement of any patent or copyright, for sale and use of Intel products except as provided in Intel's Terms and Conditions of Sale for such products.

Intel retains the right to make changes to these specifications at any time, without notice. Microcomputer Products may have minor variations to this specification known as errata.

\*Other brands and names are the property of their respective owners.

†Since publication of documents referenced in this document, registration of the Pentium, OverDrive and iCOMP trademarks has been issued to Intel Corporation.

Contact your local Intel sales office or your distributor to obtain the latest specifications before placing your product order.

Copies of documents which have an ordering number and are referenced in this document, or other Intel literature, may be obtained from:

Intel Corporation  
P.O. Box 7641  
Mt. Prospect, IL 60056-7641  
or call 1-800-879-4683

# Pentium® Processor Clock Design

<b>CONTENTS</b>	<b>PAGE</b>	<b>CONTENTS</b>	<b>PAGE</b>
<b>1.0 INTRODUCTION</b> .....	1	<b>FIGURES</b>	
1.1 General Clocking Issues .....	1	Figure 1 Common Termination Techniques .....	2
<b>2.0 Pentium® PROCESSOR, 82496 AND 82491 SYSTEM CLOCK SPECIFICATIONS</b> .....	2	Figure 2 Clock Requirements for the Pentium® Processor and CPU-Cache Chip Set .....	4
<b>3.0 AVAILABLE CLOCK DRIVERS</b> .....	7	Figure 3 An Example of an Acceptable Clock Waveform (Diodes Are Absent from the Input Model) .....	5
<b>4.0 CLOCK GENERATION FOR THE Pentium® PROCESSOR AND THE CPU-CACHE CHIP SET</b> .....	11	Figure 4 An Example of an Acceptable Clock Waveform (Diodes Are Present in the Input Model) .....	6
4.1 Clock Generation for Fully Synchronous Systems .....	12	Figure 5 An Example of an Unacceptable Clock Waveform (Diodes Are Absent from the Input Model) .....	7
4.2 Clock Generation for Divided Synchronous Systems .....	12	Figure 6 A CPU Module with the Pentium® Processor, 82496 and 82491 CPU-Cache Chip Set .....	11
4.3 Clock Generation for Asynchronous Systems .....	16	Figure 7 Examples of Clock Generation .....	12
<b>5.0 Pentium® PROCESSOR WITH 256K 82496/82491 SECOND LEVEL CACHE CLOCK DISTRIBUTION DESIGN EXAMPLES</b> .....	16	Figure 8 Clock Generation Using Clock Doubler .....	13
5.1 Clock Routing for the 256K CPU-Cache Chip Set .....	16	Figure 9 Clock Generation Using Clock Doubler .....	13
5.2 Analysis of Drivers Used in Examples .....	22	Figure 10 Clock Generation Using Clock Divider .....	14
<b>6.0 Pentium® PROCESSOR WITH 512K 82496/82491 SECOND LEVEL CACHE CLOCK DISTRIBUTION ISSUES</b> .....	32	Figure 11 Clock Generation Using Two PLLs .....	14
<b>7.0 CLOCK DISTRIBUTION FOR THE Pentium® PROCESSOR WITH OTHER SECOND LEVEL CACHES</b> .....	32	Figure 12 Clock Generation Using Two PLLs .....	15
<b>8.0 SUMMARY</b> .....	32	Figure 13 Pentium® Processor, 82496 and 82491 Clock Input Models .....	17
<b>9.0 REFERENCES</b> .....	32	Figure 14 CLK0 Layout for 256K Chip Set with Parity .....	18
<b>APPENDIX A. CLOCK DRIVER MANUFACTURERS</b> .....	A-1	Figure 15 CLK1 Layout for 256K Chip Set with Parity .....	19
		Figure 16 CLK2 Layout for 256K Chip Set with Parity .....	20



## CONTENTS

PAGE

### FIGURES

Figure 17 CLK3 Layout for 256K Chip Set with Parity .....	21
Figure 18 Motorola Waveform .....	25
Figure 19 National Waveform .....	26
Figure 20 Vitesse (Slow) Waveform .....	27
Figure 21 Vitesse (Slow) Waveform (Continued) .....	28
Figure 22 Vitesse (Fast) Waveform .....	29
Figure 23 Triquint Waveform .....	30
Figure 24 Triquint Waveform (Contd.) .....	31

## CONTENTS

PAGE

### TABLES

Table 1 Clock Signal Quality Specifications .....	3
Table 2 Clock Signal Quality Guidelines .....	3
Table 3 Clock Driver Options .....	8
Table 4 List of Clock Doubler Parts .....	15
Table 5 List of Clock Divider Parts .....	15
Table 6 Interconnect Characteristics .....	22
Table 7 Compilation of Simulation Data .....	23
Table 8 Series Termination Resistor Values for Each Line .....	24



## 1.0 INTRODUCTION

Today's high speed microprocessors place a heavy demand on clock generation and distribution. To maintain a synchronous system, well-controlled and precise clocking solutions are required. Pentium® processor, with operating frequencies of 60 MHz and 66 MHz, has tight system clock specifications. In order to bring clock signals of acceptable quality and minimal skew to the Pentium processor and the rest of the system, system designers have to contend with high speed issues for clock distribution and limited number of precise clock driver devices. In this application note, the key issues in the design of a 60 MHz or 66 MHz clock for a Pentium processor-based system will be discussed, available clock drivers will be listed and discussed, and detailed design examples of a clock solution for the Pentium processor with 256K second-level cache subsystem, using the 82496 Cache Controller and the 82491 Cache SRAMs, are provided.

The Pentium processor, 82496 Cache Controller, and 82491 Cache SRAM form a CPU-Cache core or chip set. Along with a memory bus controller (MBC), the chip set provides a CPU-like interface for many types of memory buses.

This application note is intended for system designers concerned with clock generation and distribution for the Pentium processor and CPU-Cache chip set based systems. It reflects data collected from several quarters of characterization of the Pentium processor and experience with some of the clock driver devices, as well. This application note gives readers a good understanding of the issues and solutions of high speed clocking, particularly that for the Pentium processor. The reader should be familiar with the Pentium processor and CPU-Cache chip set electrical and mechanical specifications, *Clock Design in 50 MHz Intel486™ Systems*, and transmission line theory. If not, please read materials listed in Section 9.0 before proceeding.

## 1.1 General Clocking Issues

There are two major problems with distributing clock signals at 66 MHz: clock signal quality and clock skew. At high speed, one set of effects which has been minor in slower designs is now significant—the effects of transmission line. At high frequencies and fast edge rates, long traces behave like transmission lines. The “lumped” circuit assumption which assumes instantaneous signal transmission is no longer valid. Instead, signals travel in a finite time. When a transmission line is not properly terminated, one can observe severe overshoot, undershoot and ringback, all of which degrade logical signals. Bad signal quality can cause false switching or multiple switching, and can in extreme cases damage the devices. To maintain a clean clock signal, designers must consider clock driver characteristics, signal routing, load characteristics, and transmission line termination.

There are four basic ways to terminate a transmission line, series, parallel, Thevenin, and AC terminations (Figure 1). Series termination is recommended when driver output impedance is less than the transmission line characteristic impedance (true for most TTL drivers) and the line is driving a small number of devices. Series termination consumes low power and uses only one device; however, the termination method increases signal rise and fall times. Series termination ensures good signal quality by eliminating secondary reflection off the driver end. The rest of the termination methods eliminate reflection at the load end. All of the termination methods can provide good, clean clock signals at the load. Both parallel and Thevenin terminations consume a large amount of power. Thevenin termination consumes less power than parallel but requires one more device. AC termination consumes low power but adds capacitive load to the driver and delay due to RC time constant. Design examples provided with this application note use series termination. For more information on transmission line effects and design issues, please refer to [ref. 3, ref. 4, ref. 5]

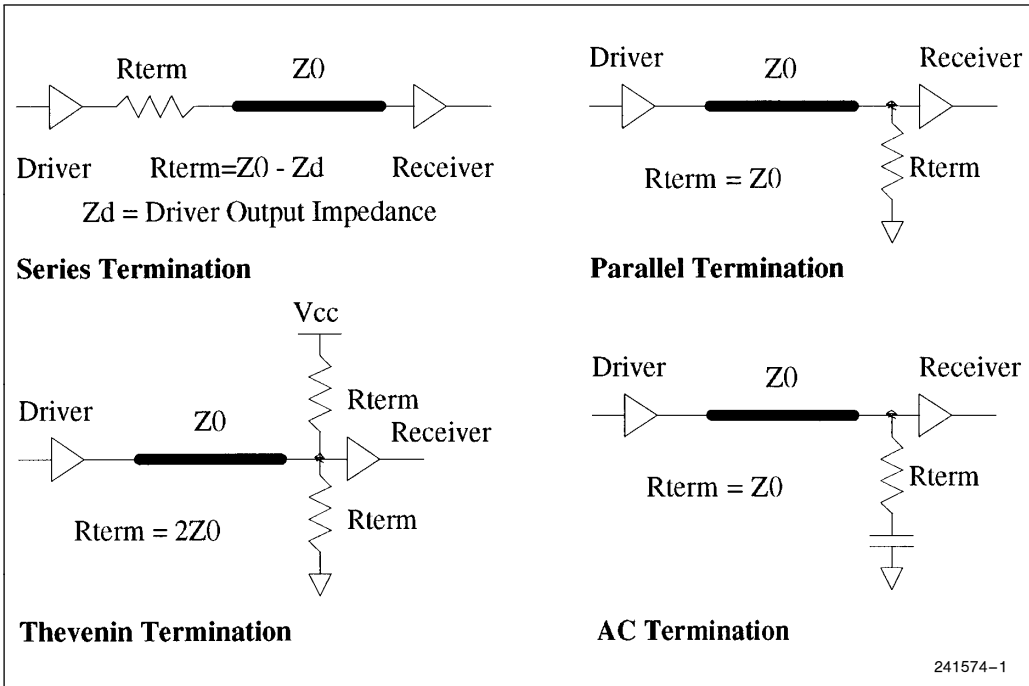

Figure 1. Common Termination Techniques

Skew is defined as the time difference between when the clock signal reaches each component. As frequency increases, there is less and less time for computation in a given clock period for a synchronous design. For a typical design, the time from one rising edge to the next is composed of the largest path-delay, setup time, propagational delay through logic elements, and skew. Clock skew then, takes away from the time available for propagational delay, thereby restricting the amount of logic done in a clock cycle. For high speed designs, skew must be minimized.

To minimize skew, designers must tune clock traces so that the propagational delay from driver through each trace to load is the same for each load. For balanced loads, tuned traces have same lengths. For unbalanced loads, trace lengths can be adjusted to make up for loading differences. If possible, designers should try to keep the loading on each clock line the same.

## 2.0 PENTIUM® PROCESSOR, 82496 AND 82491 SYSTEM CLOCK SPECIFICATIONS

System clock specifications can be divided into 2 categories: signal quality requirements and skew specifications. Clock signal quality requirements are the same for the Pentium processor and CPU-Cache chip set. Skew specifications are only required for CPU-Cache chip set.

Signal quality requirements define boundaries for acceptable signal shapes and levels. There are two parts to signal quality requirements: signal quality specifications (Table 1) and guidelines (Table 2). Please refer to the latest revision of the Pentium processor and CPU-Cache chip set specifications for more details and for the most up-to-date information.

**Table 1. Clock Signal Quality Specifications**

Symbol (5)	Parameter	Minimum	Maximum	Unit	Notes
	CLK Frequency	33.33	66.66	MHz	(1)
t2	CLK Period	15		ns	
t3	CLK High Time	4		ns	(2)
t4	CLK Low Time	4		ns	(3)
t5	CLK Rise Time	0.15	1.5	ns	(4)
t6	CLK Fall Time	0.15	1.5	ns	(4)
	CLK Stability		± 250	ps	(6), (7), (8), (9)
	V <sub>IH</sub>	2	V <sub>CC</sub> + 0.3	V	
	V <sub>IL</sub>	-0.3	0.8	V	

**NOTES:**

- Below 66 MHz only functionality is guaranteed.
- High times are measured between 2.0V crossing points.
- Low times are measured between 0.8V crossing points.
- Rise and fall times are measured between 0.8V and 2.0V.
- Symbols in Figure 2.
- Functionality is guaranteed by design/characterization.
- Measured on rising edge of adjacent CLKs at 1.5V.
- To ensure a 1:1 relationship between the amplitude of the input jitter and the internal and external clocks, the jitter frequency spectrum should not have any power spectrum peaking between 500 KHz and 1/3 of the CLK operating frequency.
- The amount of jitter present must be accounted for as a component of CLK skew between devices.

**Table 2. Clock Signal Quality Guidelines**

Parameter	Maximum	Unit	Notes
Overshoot	1.6	V	(1)
Undershoot	1.6	V	(1)
Ringback	0.8	V	(2)

**NOTES:**

- Overshoot (undershoot) is the absolute value of the maximum voltage above V<sub>CC</sub> (or below V<sub>SS</sub>). The guideline assumes the absence of diodes on the input.
- Ringback is the absolute value of the maximum voltage at the receiving pin below V<sub>CC</sub> (or above V<sub>SS</sub>) relative to V<sub>CC</sub> (or V<sub>SS</sub>) level after the signal has reached its maximum voltage level. The input diodes are assumed present.

The overshoot guideline should be used in simulations, without diodes present, to ensure overshoot (undershoot) is within the acceptable range. The ringback guideline is provided for verification in an actual sys-

tem. System designers do not have to worry about ringback if the signal does not overshoot or undershoot, respectively. Figure 2 summarizes clock waveform requirements listed in Table 1.

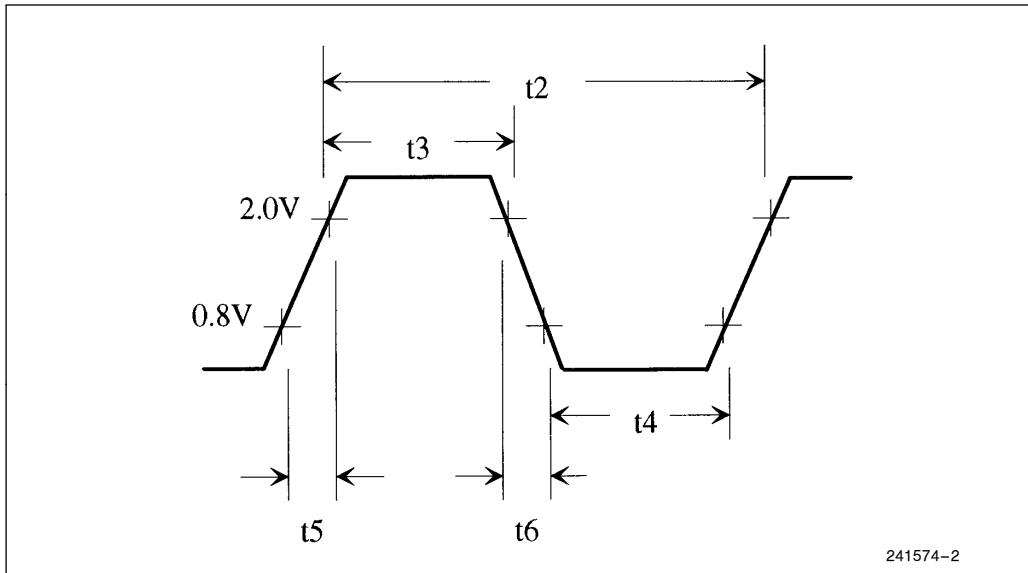

**Figure 2. Clock Requirements for the Pentium® Processor and CPU-Cache Chip Set**

Figure 3 to Figure 5 illustrates examples of acceptable and unacceptable clock waveforms. Waveform in Figure 3 is for an input model without diodes. Waveform in Figure 4 is for an input model with diodes. The diodes clamp the voltage and prevent it from going more than a diode drop above  $V_{CC}$  or below  $V_{SS}$ . Waveform

in Figure 5 is for an input model without diodes. The waveform is not acceptable for several reasons. It violates the minimum low time specification (4 ns), the maximum fall time specification (1.5 ns), and it does not follow the maximum undershoot guideline (1.6V).



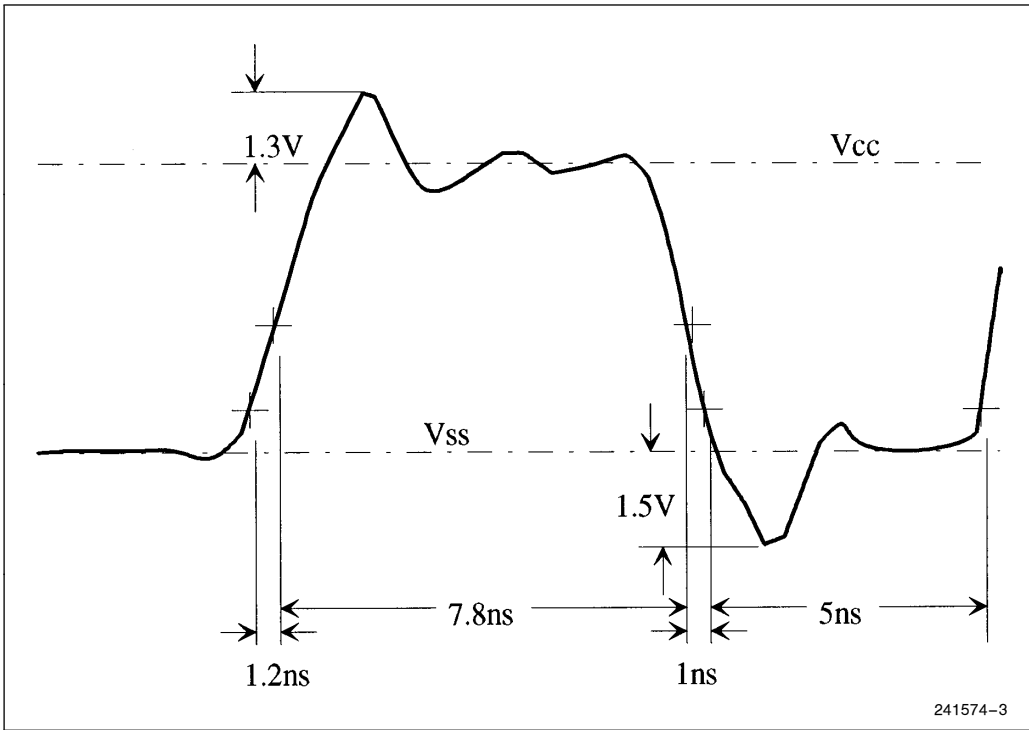

Figure 3. An Example of an Acceptable Clock Waveform (Diodes are Absent from the Input Model)

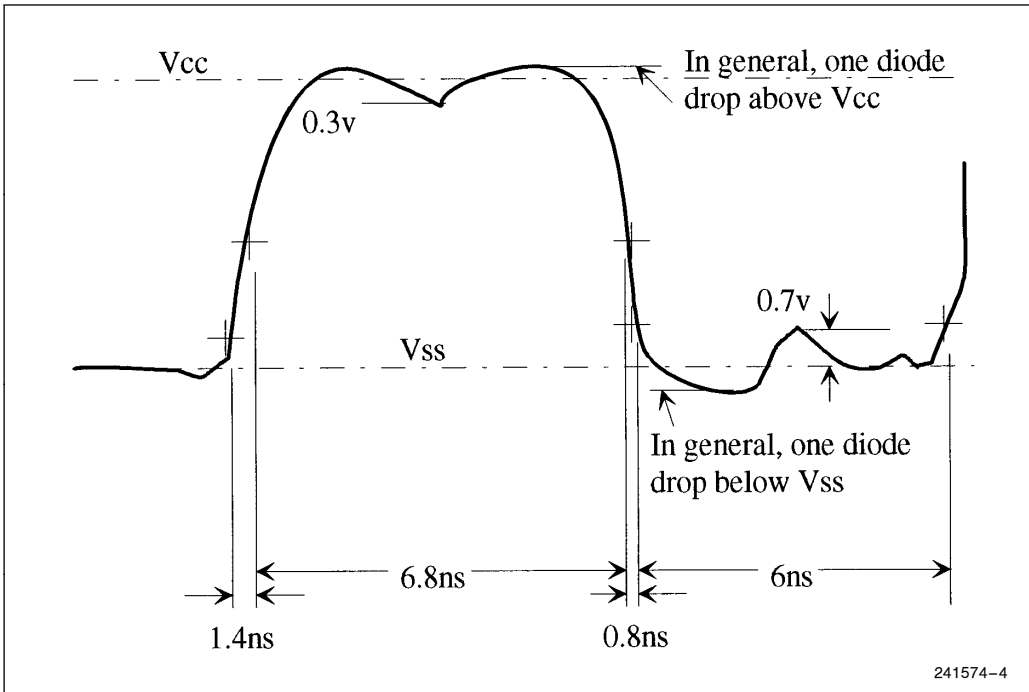
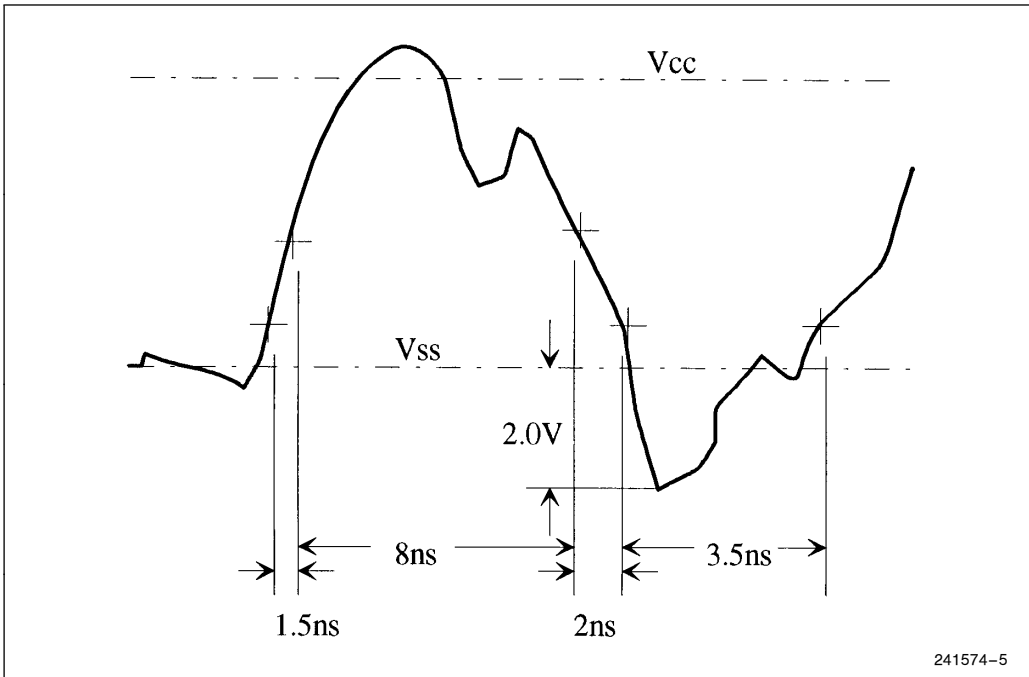

Figure 4. An Example of an Acceptable Clock Waveform (Diodes are Present in the Input Model)





**Figure 5. An Example of an Unacceptable Clock Waveform (Diodes Are Absent from the Input Model)**

Clock skews for the CPU-Cache chip set are measured at 0.8V, 1.5V, and 2.0V on the rising edge. Worst case skew between the Pentium processor and the 82496 is 0.2 ns, and worst case skew between any 82491 and either the Pentium processor or the 82496 is 0.7 ns.

### 3.0 AVAILABLE CLOCK DRIVERS

Intel has held discussions with many clock driver component companies. The intent has been to enable these companies to offer clock driver solutions that meet the Pentium processor specifications. It has also been to ensure that the super set of these companies can provide support and distribution worldwide on a schedule that closely matches the Pentium processor's availability. Based on information available, Table 3 lists a number of companies who are planning to offer solutions to meet these requirements. All the clock drivers listed in Table 3 have maximum output frequency equal or

above 66 MHz. Preliminary data sheets show that solutions listed in Table 3 meet the CPU or CPU-Cache chip set requirements. The specifications listed are based on preliminary data provided by each company and may be subject to change. Designers should contact each company for the latest specifications and availability. Some evaluation has been done by simulating an example clock layout using output models supplied by a subset of the companies listed, along with interconnect models and preliminary clock input model of the CPU-Cache chip set. For more detail on the simulations and example routing, please see Section 5.0. Intel has been and will be working closely with the listed companies to ensure they have the latest specifications for the Pentium processor. With published preliminary data sheets, all the listed parts meet either the CPU or the chip set clock specifications (including the signal quality and skew specifications). Please contact individual manufacturers for data sheets and sample availability.

Table 3. Clock Driver Options

Mfgr	Part #	Driver Type	Level In/Out	Pin-to-Pin Skew (ns)	Part-to-Part Skew (ns)	$t_r/t_f$ (0.8V-2.0V) (ns)	Clock Stability	# of Outputs (per pkg)	Spec'd Loading	Max. Freq.
Intel Spec			TTL inputs	(1)		1.5/1.5	±250 ps (2)			66 MHz and 80 MHz
AMCC	SC35XX-1	Buffer	PECL or TTL/TTL	0.5	1.0	1.5/1.5		20 Outputs Which Vary with Part #	10 pF	80 MHz
	SC44XX-80	PLL	TTL/TTL	±0.2	1.0 (9)	1.5/1.5		6-12 Outputs	35 pF	80 MHz
AT&T (7)	DA400	PLL	PECL or TTL/TTL	0.2	0.5	1.5/1.5		8@1, 0.5X (Prog Shift)	50 pF	100 MHz
	CY7B991	PLL	TTL/TTL	0.5	1.2 (6)	1.5/1.5	0.5%	4@1X 4@1, 0.5, 0.25X	50Ω/ 30 pF	80 MHz
ICS	ICS2686	PLL		0.5	0.6	1.5/1.5		5@1, 0.5X	20 pF	
Intel	85C224-100	Divider/ Buffer/PLD	TTL/CMOS	Divider 0.4 Buffer 0.5	NA	Divider 1.2/1.1 Buffer 1.4/1.1		8 @ + 1X, - 1X, 0.5X	70Ω/ 50 pF	Divider 100/50 Buffer 133
		Buffer/ Divider/PLD	TTL/CMOS	Divider 0.4 Buffer 0.5	NA	Divider 12./1.1 Buffer 1.4/1.1		8 @ + 1X, - 1X, 0.5X	70Ω/ 50 pF	Divider 58/29 Buffer 100
Motorola	MC10H646	Buffer	PECL or TTL/TTL	0.5	1.0	1.2/1.2	NA	8	50Ω/ 50 pF	100 MHz
	88915	PLL	TTL/CMOS	0.5	NA	2.5/2.5(11)	NA	5@1X 1@2X 1@.5X 1 Inverted X	50Ω	66 MHz

Table 3. Clock Driver Options (Continued)

Mfrgr	Part #	Driver Type	Level In/Out	Pin-to-Pin Skew (ns)	Part-to-Part Skew (ns)	t <sub>r</sub> /t <sub>f</sub> (0.8V–2.0V) (ns)	Clock Stability	# of Outputs (per pkg)	Spec'd Loading	Max. Freq.
National	CGS74CT2524	Buffer	TTL/CMOS	0.45	NA	1.5/1.5		4	50 pF	100 MHz
	CGS74CT2527	Buffer	TTL/CMOS	0.45	NA	1.5/1.5		8	50 pF	100 MHz
	CGS74B2528	Buffer	TTL/TTL	0.55	NA	1.5/1.5		10	50 pF	70 MHz
Pioneer	PI6B2407	PLL	TTL/TTL	±0.25	NA	1.5/1.5	100 ps	12@1, 0.5, 2X (Prog Shift)		80 MHz
TI (8)	CDC328	Buffer	TTL/TTL	0.7	NA	1.2/0.5	NA	6	500Ω/ 50 pF	Not Spec'd.
Triquint (10)	GA1085	PLL	TTL/TTL	0.25	NA	1.4/1.4	75 ps (typ.)	5@1X 4@0.5X 2@0.5X (Prog Shift)	50Ω	66 MHz
	GA1086	PLL	TTL/TTL	0.25	NA	1.4/1.4	75 ps (typ.)	9@1X 1@0.5X	50Ω	66 MHz
	GA1087	PLL	TTL/TTL	0.25	NA	1.4/1.4	75 ps (typ.)	6@1X 4@0.5X	50Ω	66 MHz
Vitesse	VSL4485	PLL	TTL/TTL	0.5	NA	1.5/1.5		6@1X 2@1, 2, 4X	50 pF	70 MHz
	VSL4586	PLL	TTL/TTL	0.5	NA	1.5/1.5		2@1X 6@1, 2, 4X	50 pF	70 MHz

**NOTES:**

- 0.7 ns between Pentium processor-82491, 82496-82491, 82491-82491. 0.2 ns between Pentium processor-82496. Assumed 0.5 ns between clock driver outputs, leaving 0.2 ns for routing or trace skew.
- See complete specification in Table 1 or the data book.
- Manufacturers listed in alphabetical order.
- Contact manufacturers for price and availability information.
- Intel does not guarantee specifications for other manufacturer's devices. All clock driver specifications listed were provided by the manufacturer and are subject to change. Designers should contact the manufacturer for the latest specification/data sheet information.
- As low as 0.75 ns in some configurations.
- First samples in March '93. Specifications may improve during characterization.
- Other Solutions are under development. Contact TI for preliminary details.
- Maximum phase error quoted in the manufacturer's data sheet for the entire frequency range.
- Other configurations available. Contact Triquint for details.
- Between 0.2 V<sub>CC</sub> and 0.8 V<sub>CC</sub>. Contact Motorola for details between 0.8 and 2.0V.

AMCC offers the SC35XX-1 series of buffered clock drivers and the SC44XX-80 series of PLL based clock drivers. The SC35XX-1 series must be driven with a TTL or PECL 2X frequency input. Each member of the series provides 20 outputs. Depending on the specific part within the series, these 20 outputs can be configured to provide the primary frequency, 1/2, or 1/4 the primary frequency. The SC3502-1 even provides 5 inverted outputs of the primary frequency. The SC44XX-80 series must be driven with a TTL input. The PLL design allows for very low skew ( $\pm 200$  ps) between the outputs. Different members of the series offer different numbers and configurations of outputs. Between 4 and 8 outputs are available at the primary frequency. These devices also allow a subset of the outputs to be configured for 1/2X or 2X the primary frequency. In addition, the PLL allows the outputs to be skewed in phase from one another.

AT&T DA400 is a PLL clock driver. Its inputs can be driven by TTL or PECL levels. Eight outputs are provided. They can be configured for the primary frequency or 1/2X the primary frequency. In addition each output has a programmable delay line which allows 1/32 or 1/64 increments of the clock period of delay between outputs.

Cypress's CY7B991 is a PLL clock driver. It requires a TTL input and is able to drive 8 outputs. A subset of the outputs can be configured as 1/2X, 1/4X, or inverted outputs. As with other PLL solutions, the skew between outputs is small and the outputs can be configured for a fixed amount of delay or skew between outputs.

ICS's ICS2686 is a PLL clock driver. Five outputs are available. Both primary and 1/2X frequencies are available. The ICS2686 has been designed to work with the 74ABT240 type buffer to provide more than 5 outputs. A unique feature of the ICS2686 is the multiple feedback inputs. This feature allows synchronizing multiple outputs at their destination or load with the input clock.

Intel's 85C224-100 is a "20V8" architecture programmable logic device. From its TTL inputs it provides 8 TTL outputs which can be configured to provide 1X, 1X inverted, and 1/2X versions of the primary frequency, in any combination. When programmed to function as a frequency divider, the primary frequency can be as high as 100 MHz and the 1/2X frequency outputs will

maintain output skew below 400 ps. When programmed to operate as a straight 1X buffer, it supports frequencies of up to 133 MHz with less than 500 ps of output skew. The 85C224-100 provides a combination of superior output signal quality including fast rise and fall times and low output skew. A particularly unique feature of the 85C224-100 is in its programmable logic circuitry. Its flexibility satisfies programmable logic needs such as control line signals and widespread glue logic. With this minimized output skew PLD, a single 28-pin PLCC can provide low output skew clock distribution, frequency division, and programmable logic; for the low price of a 20V8 PLD.

Motorola offers both a buffered and a PLL clock solution. Motorola's 10H646 is a buffered clock driver. It offers both TTL and ECL inputs which supports backplane routing using ECL levels. The clock driver's outputs are clamped to 3V, not  $V_{CC}$ . 10H646's output stage has similar rise and fall output resistances. Similar rise and fall output resistances makes series termination easier since the termination resistance is the difference between the characteristic impedance of the transmission line connecting the output to the load and the driver's output impedance. 10H646 has 8 1x outputs. As a straight buffer, 10H646 does not offer any multiples of the input besides 1x. The Motorola 88915 is a PLL clock driver. It provides a 0.5 ns skew between outputs. The 88915 provides 5 1X outputs along with 1 2X, 1 0.5X, and 1 inverted X outputs.

National's clock buffers are packaged to function reliably at high frequencies. Their output rise and fall resistances are approximately equal. The CGS74CT2524 and 2527 provide 0.45 ns of output skew. The CGS74CT2528's output skew, 0.55 ns, allows for only 0.15 ns skew due to board traces or any unbalanced loading effects when using the 82496/82491 cache, however this amount may be sufficient for other cache solutions. These parts offer a range of 4, 8, and 10 outputs. The CGS74CT2524 and 2527 have CMOS level outputs, which transition from rail to rail.

Pioneer's PI6B2407 is a PLL clock driver. From its TTL input, it provides twelve TTL outputs, which can be configured to operate at 1X or 2X the input frequency. In addition, the outputs can be phase adjusted from the input clock. The PI6B2407 is able to provide  $\pm 0.25$  ns of skew between outputs while maintaining the fast 1.5 ns rise and fall times.

Texas Instruments' ABT328 driver provides six outputs with an output skew of 0.7 ns. Please contact Texas Instruments for the availability of 0.5 ns output skew parts. 0.7 ns output skew is too large for the chip set application. In the design example on Section 5.0, 0.5 ns output skew is assumed. As a buffered driver, the ABT328 offers only 1x outputs.

TriQuint's GA1086 is a Gallium Arsenide-based product. It takes a 66 MHz input and produces nine 66 MHz outputs and one 33 MHz output. The availability of a low skew 33 MHz output facilitates clock distribution for systems that have synchronous 33 MHz memory buses. Since the part is phase-lock-loop based, one of the outputs can be fed back to the input so that all the outputs are synchronized with the input clock. Such a set up is ideal for cascading clock drivers to achieve maximum fanout. The specified output skew of the GA1086 is 0.25 ps, the smallest skew number available. Triquint also offers the GA1085 and GA1087. These products are similar to the GA1086, however, they offer different combinations of outputs between 1X and 0.5X.

Vitesse's VSL4485 is also a Gallium Arsenide-based product. It offers 1x, 2x, and 4x options on two of its eight outputs. Thus, to obtain both 33 MHz and

66 MHz signals with low skew, for example, the clock input frequency of the VSL4485 can be 33 MHz. For the chip set application, two 66 MHz outputs are not enough, and thus cascading another driver is necessary. Alternatively, the input can be 66 MHz and all of its outputs can be at 66 MHz. It offers 0.5 ns output skew, and a low effective delay. In addition, VSL4485 can generate programmable, multiple phase relationships among its outputs.

#### 4.0 CLOCK GENERATION FOR THE Pentium® PROCESSOR AND THE CPU-CACHE CHIP SET

Clock generation is the generation of copies of clock signals from a signal oscillator or any other source which then are distributed to the various loads. The function of a clock driver is to generate multiple copies of clocks from a single source. In general, Pentium processor-based systems have three types of memory interface: fully synchronous, divided synchronous, and asynchronous. Each interface requires different methods of clock generation. The basic setup of a processor card is illustrated symbolically in Figure 6. Depending on the configuration, the Clock In signal can come from the memory bus or a separate oscillator.

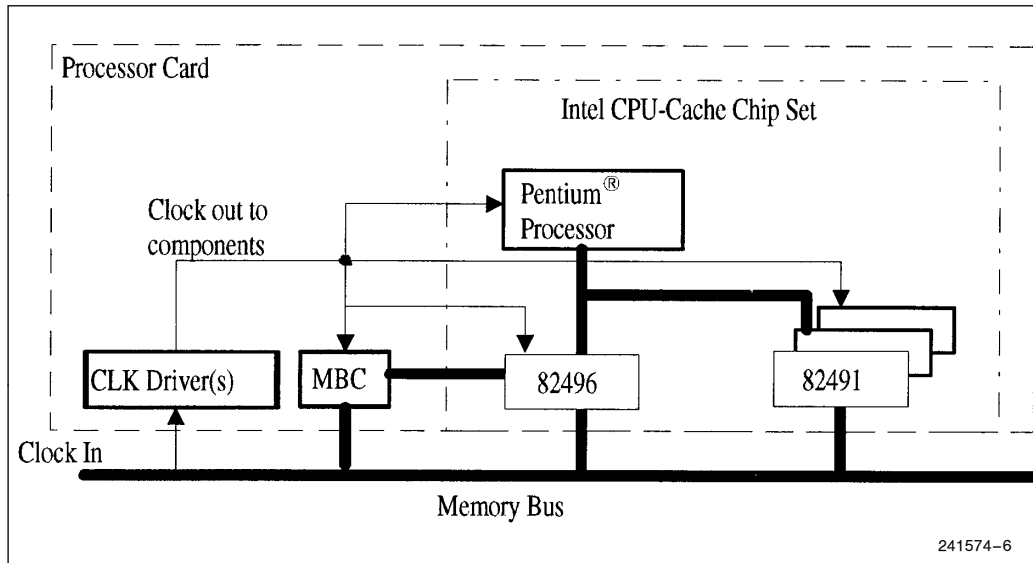

Figure 6. A CPU Module with the Pentium® Processor, 82496 and 82491 CPU-Cache Chip Set

### 4.1 Clock Generation for Fully Synchronous Systems

A fully synchronous system is one which everything in the system runs synchronous to the CPU. In particular, the memory bus interface is synchronous to the CPU. In Figure 6, the memory bus is at 66 MHz, synchronous to the CPU module. Clock In signal must be synchronous to the memory bus. Clocking for this case involves the generation of tightly controlled copies of clock signals that are distributed to all the clocked parts. The task of clock generation and distribution is the most difficult for this type of set up. All copies of clock signals must come from a single source, and must be deskewed appropriately. For Pentium processor-based systems that run at 66 MHz, the most critical parameter in choosing a clock driver is its output skew, as well as its part-to-part skew if more than one driver is needed. Since all the clock signals are at 66 MHz, only 1x outputs are needed. All of the drivers listed in Section 3.0 can be used here.

For a fully synchronous configuration, it is likely that a single clock driver cannot provide enough copies of clock signals. Then, some kind of cascading of drivers is necessary. Figure 7 shows two ways of clock generation by cascading drivers. Tskew is the total worst case skew at outputs of CD2 and CD3. Tpp23 is the worst case part-to-part skew between CD2 and CD3. Tos2 is the worst case output skew of CD2, assuming the worst case output skew of CD3 is the same as Tos2. Tos1 is the worst case output skew of CD1. Ttol2 is the feedback tolerance of CD2. Feedback tolerance is the phase tolerance between the feedback input and the reference clock. Typically, Ttol2 is a small number. For the examples in Figure 7, it is assumed that only the second level drivers feed the clock signals to the loads. Otherwise, for part a, signals from CD2 will be later than signals from CD1 by the propagational delay of CD2 which is typically between 6 ns to 8 ns.

For the examples in Figure 7 clock signals for the CPU-Cache chip set must be derived from one clock driver outputs only so that the 0.2 ns and 0.7 ns skew specifications can be met. In part a, Tskew, the sum of Tpp23, Tos2, and Tos1 is the worst case skew which is the skew between an output of CD2, and an output of CD3. The output skew of CD1 (Tos1) causes the inputs to CD2 and CD3 to arrive at different times. The difference in propagational delay which is Tpp23, further skews the outputs of CD2 and CD3. If the part-to-part skew does not include output skew, different outputs from CD2 and CD3 can also be skewed by the output skew. For part b, Tskew, the sum of Ttol2, Tos2, and Tos1, is also the worst case skew between the outputs of CD2 and the outputs of CD3. Once again, Tos1 causes

the inputs to CD2 and CD3 to arrive at different times. The feedback in CD2 synchronizes all its outputs in the input. The feedback output of CD2 is different from the input reference clock only by Ttol2. All the other outputs are further skewed from the feedback output by Tos2. The analysis for CD3 is the same.

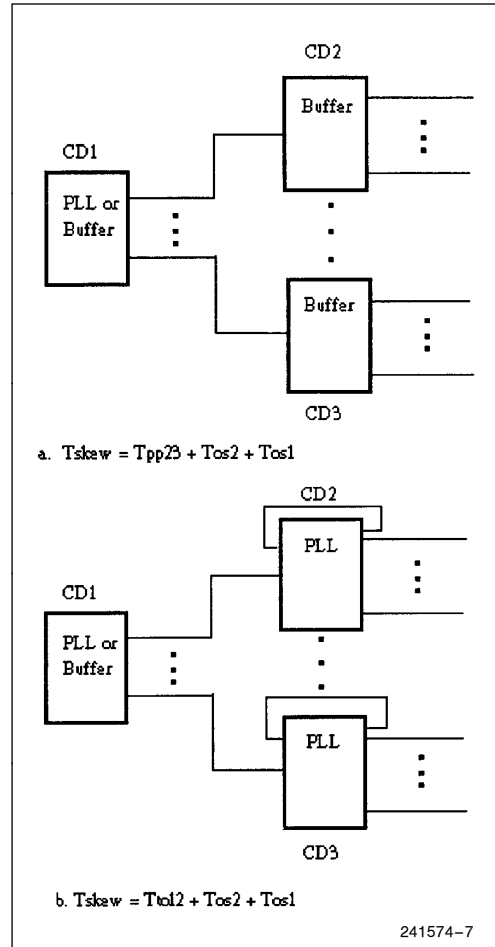

Figure 7. Examples of Clock Generation

### 4.2 Clock Generation for Divided Synchronous Systems

For a divided synchronous system, the memory bus is at half the speed of the CPU-Cache chip set; i.e.,



the memory bus runs at 33 MHz for the Pentium processor or the CPU-Cache chip set based systems. A 33 MHz reference clock (Clock In) can come from the backplane from which all the clocks serving the CPU-cache module (Figure 6) must be synchronized. The memory bus controller (MBC) itself requires both 33 MHz and 66 MHz clocks. For this configuration, clock drivers that can provide both 33 MHz and 66 MHz outputs are needed.

There are several ways of providing the two frequencies. They are shown in Figure 8 through Figure 12. Tskew is the worst skew between 33 MHz signals and

66 MHz signals. The skews among 66 MHz signals or among 33 MHz signals are simply the output skew of the driving devices. Ttolpll is the PLL CLK doubler or PLL CLK divider's feedback tolerance. Tospll is the PLL CLK doubler or PLL CLK divider's worst case output skew. Tppbuf is the worst case part-to-part skew of the second level buffers. Those buffers can be phase-lock-loops also in which case Tppbuf is the feedback tolerance of the PLLs if feedback is used. Tosbuf is the worst case output skew of the second level buffers. Tos1 is the output skew of CD1, Ttol2 is the feedback tolerance of CD2, and Tos2 is the output skew of CD2.

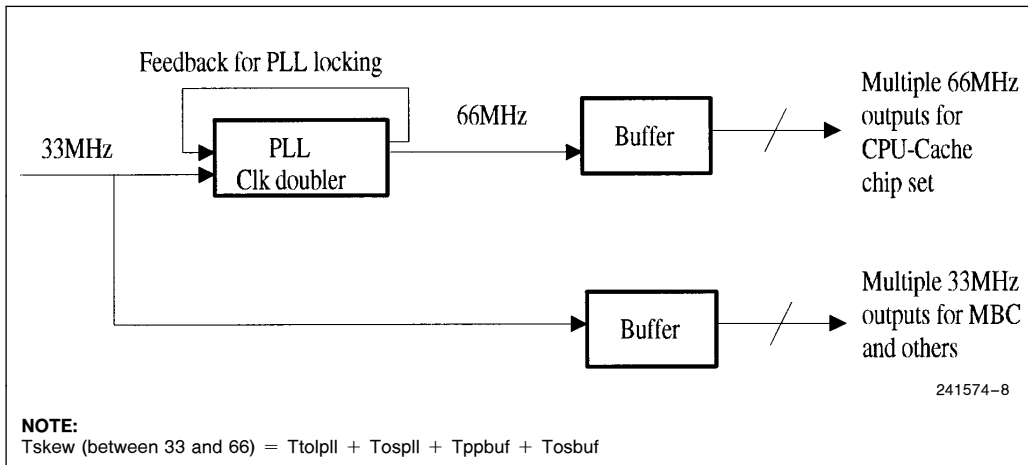

Figure 8. Clock Generation Using Clock Doubler

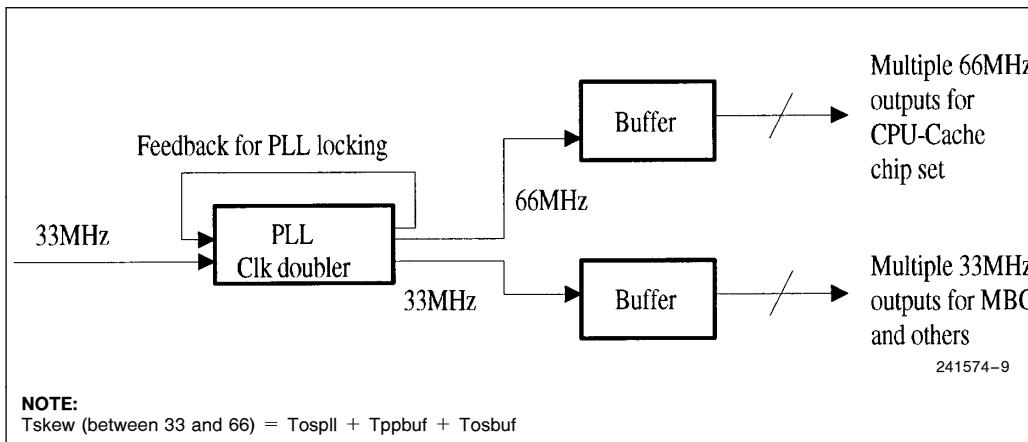

Figure 9. Clock Generation Using Clock Doubler

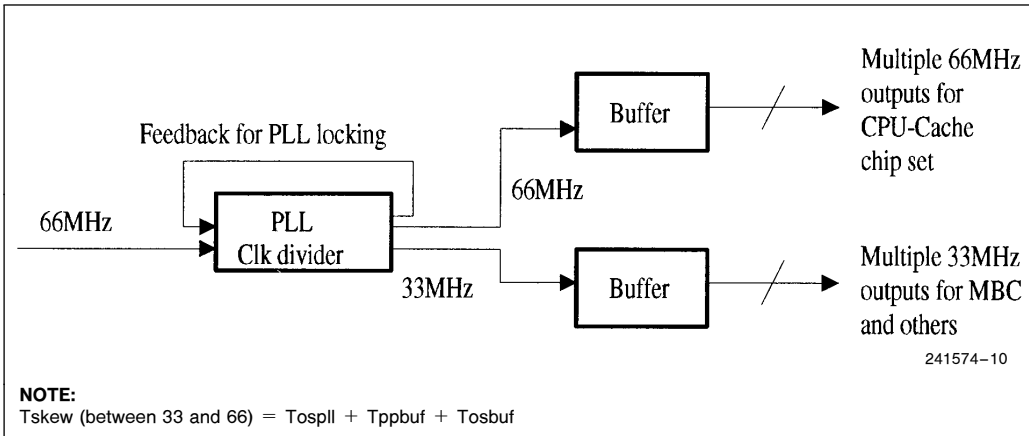

Figure 10. Clock Generation Using Clock Divider

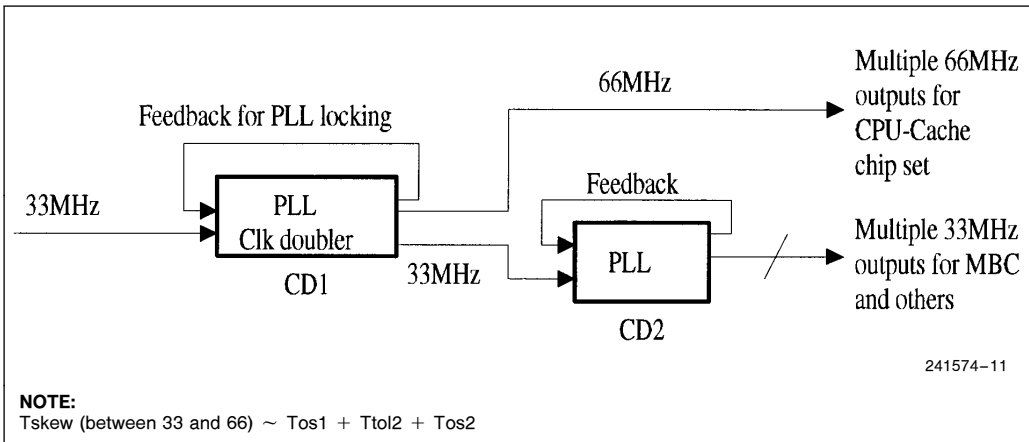
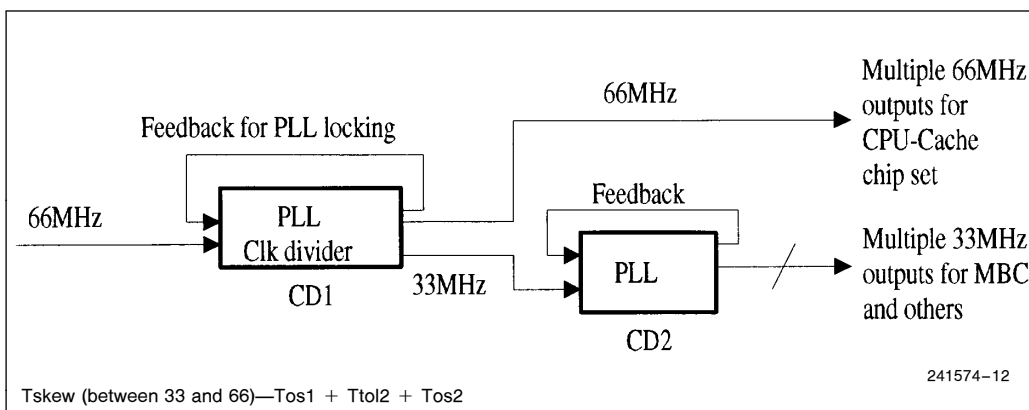

Figure 11. Clock Generation Using Two PLLs

**Figure 12. Clock Generation Using Two PLLs**

Since the outputs of the first level PLL CLK doublers and dividers go directly to inputs of another clock driver, the signal quality requirements of these outputs are not as stringent as if the outputs drive the loads of the Pentium processor and others. One of the functions of a clock driver is to buffer and clean up a clock signal in addition to generating multiple copies of the same. However, the output skew of the PLL used for the first level is very important. Depending if feedback is used, the feedback tolerance is of importance. When choosing a clock driver, also be sure that its maximum output frequency is greater than 66 MHz for 66 MHz outputs and 33 MHz for 33 MHz outputs. The parts listed in Table 4 and Table 5 are examples of devices that can be used as first level drivers as illustrated in Figure 8 through Figure 12.

**Table 4. List of Clock Doubler Parts**

Manufacturer	Part #	Driver Type	# of Outputs (per pkg)
Motorola	88915	PLL	1 @ 2x 6 @ 1x (1) 1 @ 0.5x
Motorola	88916	PLL	1 @ 2x 4 @ 1x (1) 1 @ 0.5x
TI	ABT338	PLL	1 @ 2x 4 @ 1x 1 @ 0.5x
Vitesse	VSL4485	PLL	6 @ 1x 2 @ 1, 2, or 4x

**NOTES:**

- One of the outputs is inverted.
- This list is not meant to be complete. Other solutions may be available.

The phase-lock-loop drivers listed in Table 4 can be used to drive the Pentium processor loads directly if only one copy of 66 MHz clock signal is needed. In this case, the second level buffers are not necessary if the driver used can provide enough 33 MHz copies. Intel has not done formal analysis on these parts.

**Table 5. List of Clock Divider Parts**

Manufacturer	Part #	Driver Type	# of Outputs (per pkg)
Motorola	88915	PLL	1 @ 2x 6 @ 1x (1) 1 @ 0.5x
Motorola	88916	PLL	1 @ 2x 4 @ 1x (1) 1 @ 0.5x
Texas Instruments	ABT338	PLL	1 @ 2x 4 @ 1x 1 @ 0.5x
Texas Instruments	ABT337	Buffer	4 @ 1x 4 @ 0.5x
Texas Instruments	ABT339	Buffer	4 @ 1x 4 @ 0.5x
TriQuint	GA1086	PLL	9 @ 1x 1 @ 0.5x

**NOTES:**

- One of the outputs is inverted.
- This list is not meant to be complete. Other solutions may be available.

Table 5 lists examples of clock drivers that offer divided by 2 outputs. These devices can be used as the first level drivers illustrated in Figure 8 through Figure 12. Depending on the number of 66 MHz copies and 33 MHz copies needed, the second level buffers may not be necessary. Again, Intel has not performed any formal analysis on these parts.

### 4.3 Clock Generation for Asynchronous Systems

If the memory bus is not synchronized with the CPU or CPU-cache module, clock generation for the system is easier compared with the two configurations above. However, clock synchronization for the Pentium processor, 82496, and 82491, as well as the clocks for the MBC is still a concern. In order for the MBC to communicate properly with the CPU-Cache chip set, some synchronized clocks at 66 MHz are needed. Since the system is asynchronous to the CPU-Cache chip set, the number of synchronous MBC clock signals is less than the synchronous case. The examples in Section 5.0 illustrate how the synchronization is done. Since the system is asynchronous, one can use a different clock source for the CPU-Cache chip set from the rest of the system.

### 5.0 Pentium® PROCESSOR WITH 256K 82496/82491 SECOND LEVEL CACHE CLOCK DISTRIBUTION DESIGN EXAMPLES

After a clock generation scheme is determined, careful analysis must be done on clock distribution to ensure

minimal skew and proper rise and fall times. Clock distribution is the connection between clock driver outputs and clock inputs of the components that need clocking. Preliminary analysis has been done on several of the drivers listed in Section 3.0. The following examples show in detail how to terminate transmission lines properly, tune clock traces to minimize board trace skew, and validate the usefulness of the drivers to the CPU-Cache chip set using models from the manufacturers. The examples have been done using preliminary or typical models for the devices involved. They are meant as an example of the process designers can use when selecting and routing a clock circuit. Although the examples only show the clock distribution for the CPU-Cache chip set, the same principles can be applied to distribution to the memory bus controller (MBC) and other parts.

### 5.1 Clock Routing for the 256K CPU-Cache Chip Set

Analysis for CPU-Cache chip set clock routing is done using first order input models for the three chips, shown in Figure 13. Specific to CLK inputs, the models shown are **typical models** based on on-going simulation efforts, and are subject to change. Refer to the Intel data books or contact Intel for the latest models (including minimum and maximum conditions). The models include package inductance, package capacitance, and input buffer capacitance of the clock pins.



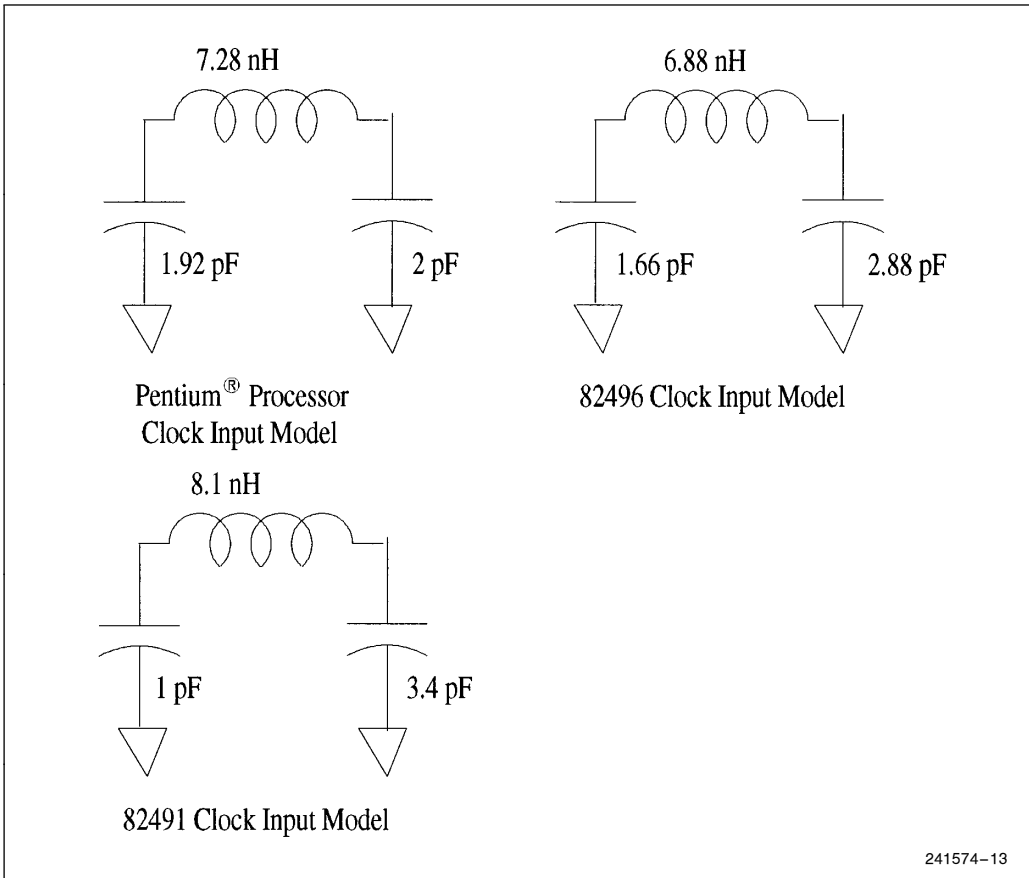

Figure 13. Pentium® Processor, 82496 and 82491 Clock Input Models



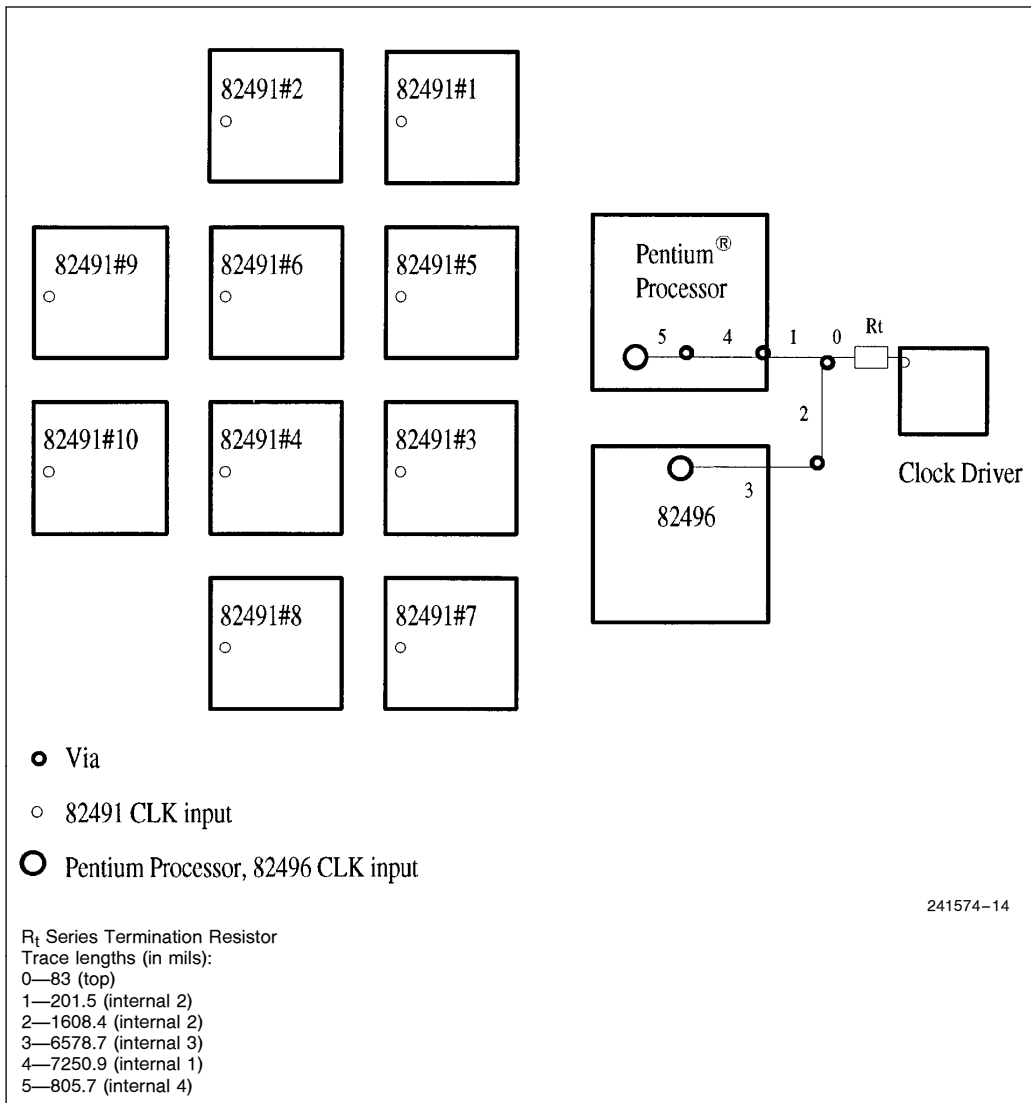

Figure 14. CLK0 Layout for 256K Chip Set with Parity

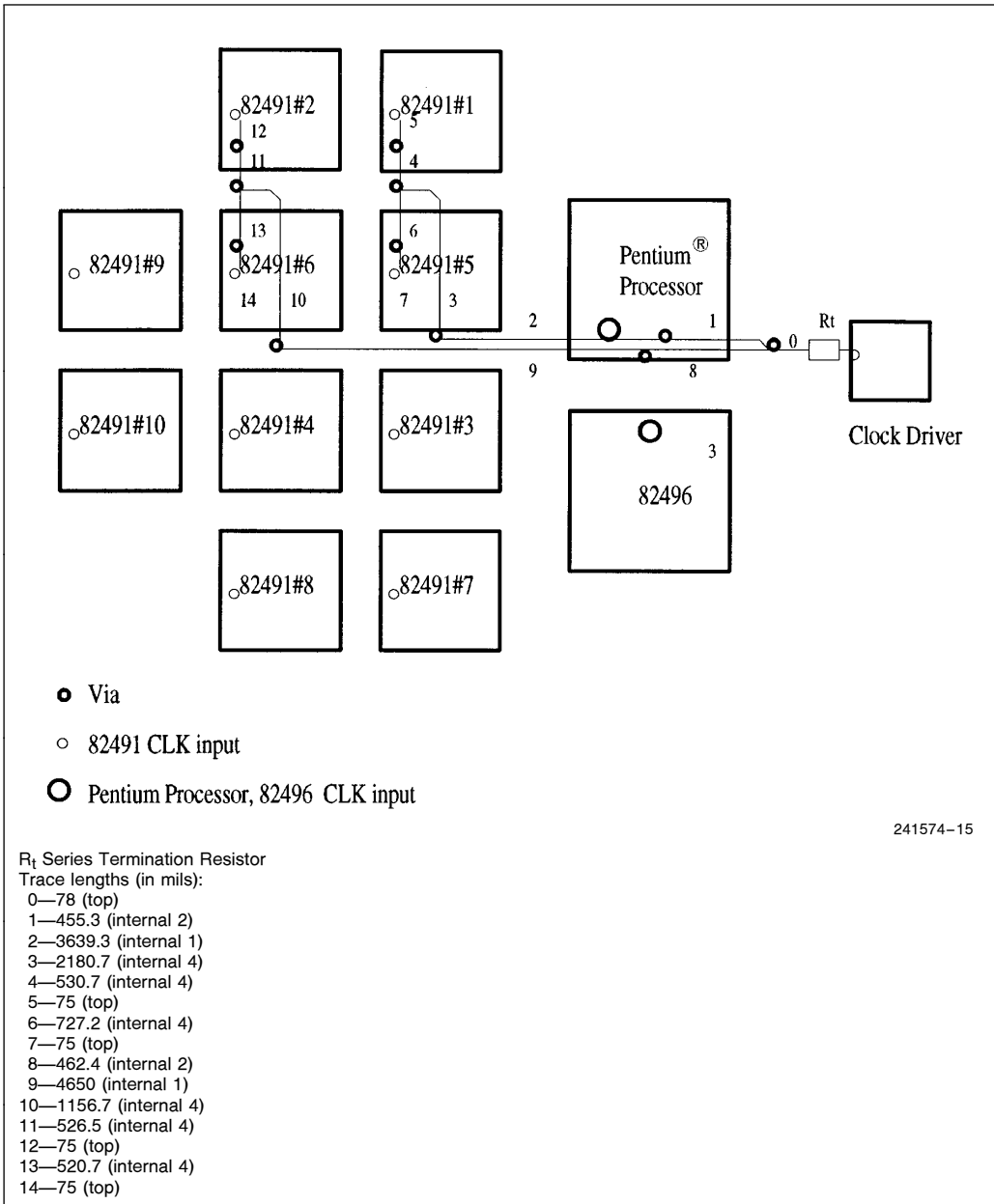

Figure 15. CLK1 Layout for 256K Chip Set with Parity

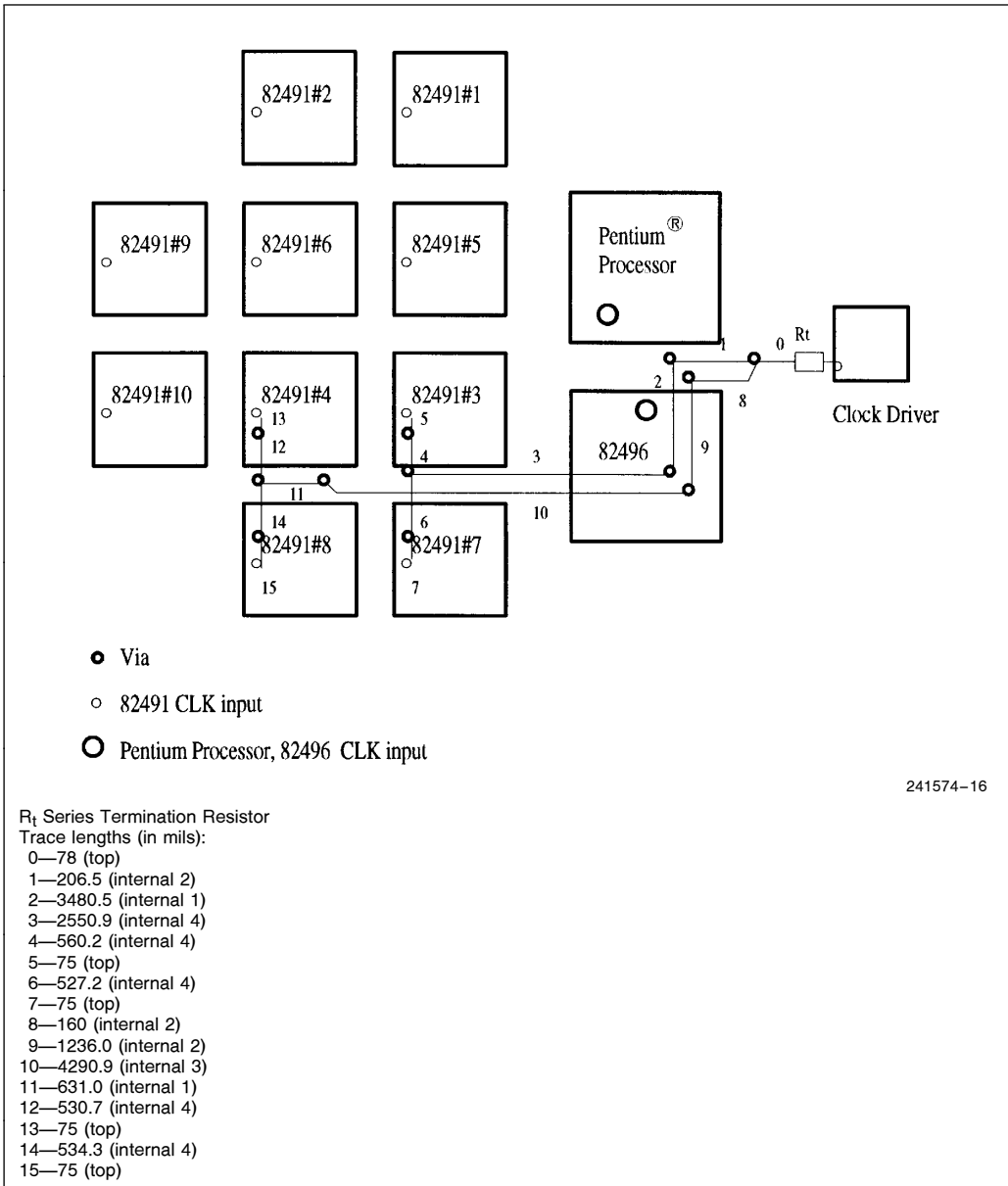

Figure 16. CLK2 Layout for 256K Chip Set with Parity



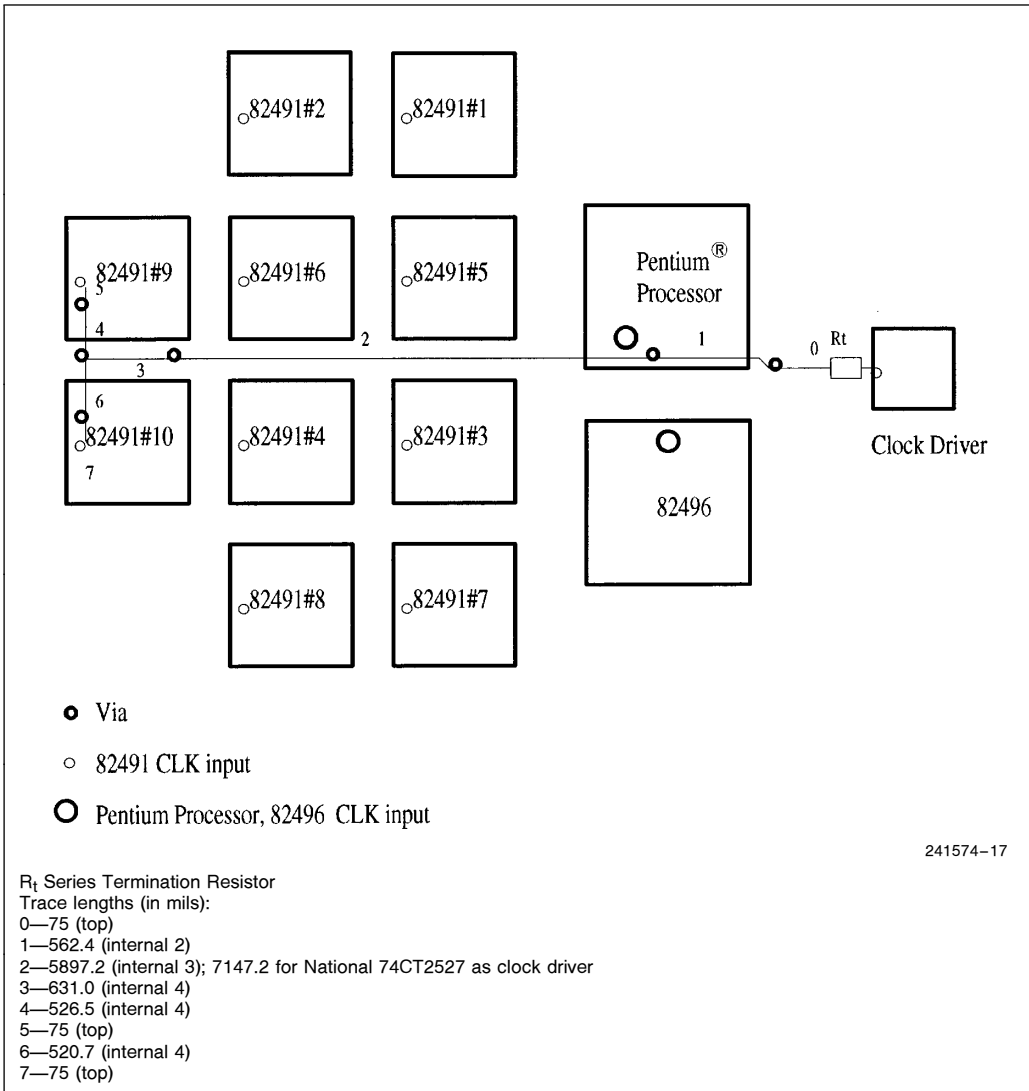

Figure 17. CLK3 Layout for 256K Chip Set with Parity

Figure 14 through Figure 17 show how clock signals are distributed from the clock driver to each component in the CPU-Cache chip set. Each clock line is tuned to minimize skew. Series termination is used on each line. Since the 82491, numbers 9 and 10, are parity chips, they are grouped onto the same driver output. Since the skew requirement between the Pentium processor and the 82496 is very tight (0.2 ns), they are also on the same driver output. All the loads on the same driver output can be tuned to have close to zero skew. Loads on different outputs, however, must contend with the output skew of the driver. CLK0 through CLK2 are laid out such that they branch off very close to the driver. For these lines, the transmission line characteristic impedance that the clock driver output sees can be treated as two resistors in parallel. In other words, the driver output sees half the impedance for CLK0, CLK1, and CLK2. The advantage of this scheme is that the value of the termination resistor is reduced dramatically. A smaller termination resistor helps faster rise and fall times. For CLK3, the branch off is at the end of the line, and thus the driver output sees the full characteristic impedance.

To achieve minimal skew, all the loads should be balanced, i.e., all the loads should be the same. For this design example, CLK1 and CLK2 have about twice the loads of CLK0 and CLK3. The load imbalance will add to the output skew quoted by manufacturers since on data sheets, manufacturers generally quote output skew for balanced loads. Since heavier loads see the transmitted signal later than lighter loads assuming the transmission lines are of the same length, traces for the lighter loads can be made longer to compensate for the discrepancy. CLK0 and CLK3 have longer traces from driver output to load than CLK1 and CLK2 traces. Since heavier loads (higher capacitance) have a longer rise time, and since for the CPU-Cache chip set skew measurements are taken at 0.8V, 1.5V, and 2.0V, to minimize skew at all free points, the termination resistors for CLK1 and CLK2 should be smaller than the termination resistors on CLK0. However, a smaller termination resistor than the value needed to perfectly terminate the line will result in a larger undershoot. When choosing termination values, it is a trade off among rise/fall times, skew, and undershoot.

When choosing a termination value, it is important to know the output impedance of the driver. For many TTL drivers, output rise impedance is different from output fall impedance. [Reference 3, Section 9] shows how to measure output impedance, or the driver manufacturer can be contacted for the information. Typically, output fall impedance is 5Ω–10Ω, and rise impedance is 5Ω–50Ω.

Figure 14 through Figure 17 are extensions to the layout topologies in the *Pentium® Processor, 82496, and 82491 256K CPU-Cache Chip Set Layout Example*. The routing topologies 15–18 shown in the example route the clock signals from the Pentium processor, 82496, and all the 82491's to the outside. The layout examples shown in this application note (Figure 14 through Figure 17) take the layout all the way to the clock driver, complete with termination. Although in the example, clock signals are routed toward the bottom and in the examples here, the clock signals are routed toward the side, the same principles apply. If routing toward the bottom is preferred, the same layouts as illustrated in Figure 14 through Figure 17 can be used with little or no modification.

## 5.2 Analysis of Drivers Used in Examples

Output models for MC10H646, CGS74CT2527, GA1086, and VSL4485 are used to drive the clock network described in Section 5.1. The clock networks shown in Figure 14 through Figure 17 were used. The simulations assume no variation in characteristic impedance and propagation speed for the board traces. Fast and slow simulations were performed. Three sigma clock driver models are used when available. Board traces are assumed to have plus/minus 10% variation in characteristic impedance and propagational speed. Table 6 shows the range of trace characteristics. Slow simulations assume the highest operating temperature the drivers expect to see, and slow interconnect characteristics. Fast simulations assume operating temperature to be zero and fast interconnect characteristics.

**Table 6. Interconnect Characteristics**

Corner	Trace Type	Z0(1) (Ω)	TD(2) (ns/ft)
Slow	Inner	58.5	2.41
Fast	Inner	71.5	1.85
Slow	Surface	72	2.05
Fast	Surface	108	1.35

### NOTES:

1. Characteristic Impedance
2. Propagational Speed

Since simulation can only account for skew due to board trace and load imbalance, total skew is assumed to be the sum of the worst case output skew published by driver manufacturers and skew from simulation. Skew from simulation is derived by using identical driver models for each driver output, thus assuming zero

output skew. The board traces and termination resistances are tuned with 0.5 ns output skew in mind which leaves 0.2 ns for trace skew. For TriQuint's GA1086, the output skew is 0.25 ns; thus, there is a larger window for trace skew. Table 7 summarizes simulation results of the tightest parameters for each driver. All of the drivers can meet the 4 ns minimum high and low times easily. Most clock drivers guarantee a 45/55 duty cycle, which exceeds Intel's requirement.

Series termination resistors are chosen to minimize skew and undershoot. To achieve similar rise time for each load, termination resistance values are smaller for heavier loaded lines such as CLK1 and CLK2 compared to the resistance values for CLK0. Since CLK3 splits off at the end of the line, its termination value is about twice as CLK0's. Table 8 lists the termination values for each line and for each driver. Waveforms for each driver are attached. Notice the signals at the CLK

input for each load is relatively clean whereas the signals at the driver side are not. Since the clock signals are only important to the component receiving the signal, how dirty the signal is at the driver end is not important, providing that the signal does not cause any damage or other ill effects on the driver.

Figures attached in this section show some waveforms from the simulations. V(201) is the voltage at the Pentium processor clock input, V(202) is the voltage at the 82496 clock input, and V(213), V(214), V(217), and V(218) are voltages at the 82491 clock inputs for the 82491s on CLK1 line. For 74CT2527, V(8) is the voltage at driver output, V(100) is the voltage at the junction of the series termination resistor and the beginning of board trace. For 10H646, V(9) is the voltage at driver output, V(20) is the voltage at the junction of the series termination resistor and the beginning of board trace.

**Table 7. Compilation of Simulation Data**

Mfr.	Clock Driver	Worst Skew P5-C5C (ns) <sup>(1)</sup>			Worst Skew C8C-Others (ns)			Worst Skew C8C (No Parity) (ns) <sup>(2)</sup>			Undershoot (-mV) <sup>(3)</sup>			Tr/Tf (ns) <sup>(4)</sup>		
		Slow	Fast	Spec	Slow	Fast	Spec	Slow	Fast	Spec	Slow	Fast	Spec	Slow	Fast	Spec
Motorola	10H646	0.021	0.023	0.2	0.65	0.67	0.7	0.65	0.67	0.7	468	816	1600	0.90/ 1.13	0.74/ 0.67	1.5/ 1.5
National	74CT2527	0.0071	(5)	0.2	0.67	(5)	0.7	0.61	(5)	0.7	285	(5)	1600	1.14/ 0.42	(5)	1.5/ 1.5
TriQuint	GA1086	0	0	0.2	0.55	0.45	0.7	0.45	0.45	0.7	150	400	1600	0.9/ 1.9 (6)	0.6/ 1.2	1.5/ 1.5
Vitesse	VSL4485	0.02	0.05	0.2	0.7	0.57	0.7	0.66	0.57	0.7	275	800	1600	0.95/ 0.78	0.78/ 0.6	1.5/ 1.5

**NOTES:**

1. All Skews are worst case numbers
2. Not using the parity chips
3. Worst Undershoot of all the CLK nodes
4. Slowest rise and fall times of all the CLK nodes
5. Only typical model at 25°C is available. Thus, only simulation performed is with slow interconnect corner
6. Simulation done on driver slow corner. Device specification for t<sub>r</sub> is 1.4 ns worst case. Device was still under development when simulation was done. Please contact TriQuint for more information.





Clock distribution method for the memory bus controller (MBC) is very similar to that of the chip set. When distributing clocks for the MBC, be sure to load each driver output with similar loads as for the chip set, and route clock traces with similar lengths as for the chip set. For example, CLK1 and CLK2 have an aggregate load of about 20 pF, and the total clock trace length is about 7" from driver output to a load. To minimize the clock skew of the MBC clock from loads on CLK1 and CLK2 lines, the clock lines should fan out 2.9 pF per inch. Also, be sure to terminate the line properly. It is important to keep the loading similar to the loadings on clock lines of the chip set if skew is to be kept close to 0.7 ns. Adjusting trace lengths and termination resistance can compensate for load imbalance to a degree, but not perfectly and not always.

Simulations results provided here are based on best available models at the time. Some models were for parts still under development at the time of simulation. Therefore, the simulation results are subject to change.

**Table 8. Series Termination Resistor Values for Each Line**

Manufacturer	Clock	CLK Line	R <sub>t</sub> (Ω)
Motorola	10H646	CLK0	26
		CLK1	20
		CLK2	20
		CLK3	59
National	74CT2527	CLK0	20
		CLK1	15
		CLK2	15
		CLK3	45
TriQuint	GA1086	CLK0	30
		CLK1	30
		CLK2	30
		CLK3	50
Vitesse	VSL4485	CLK0	32
		CLK1	23
		CLK2	23
		CLK3	48



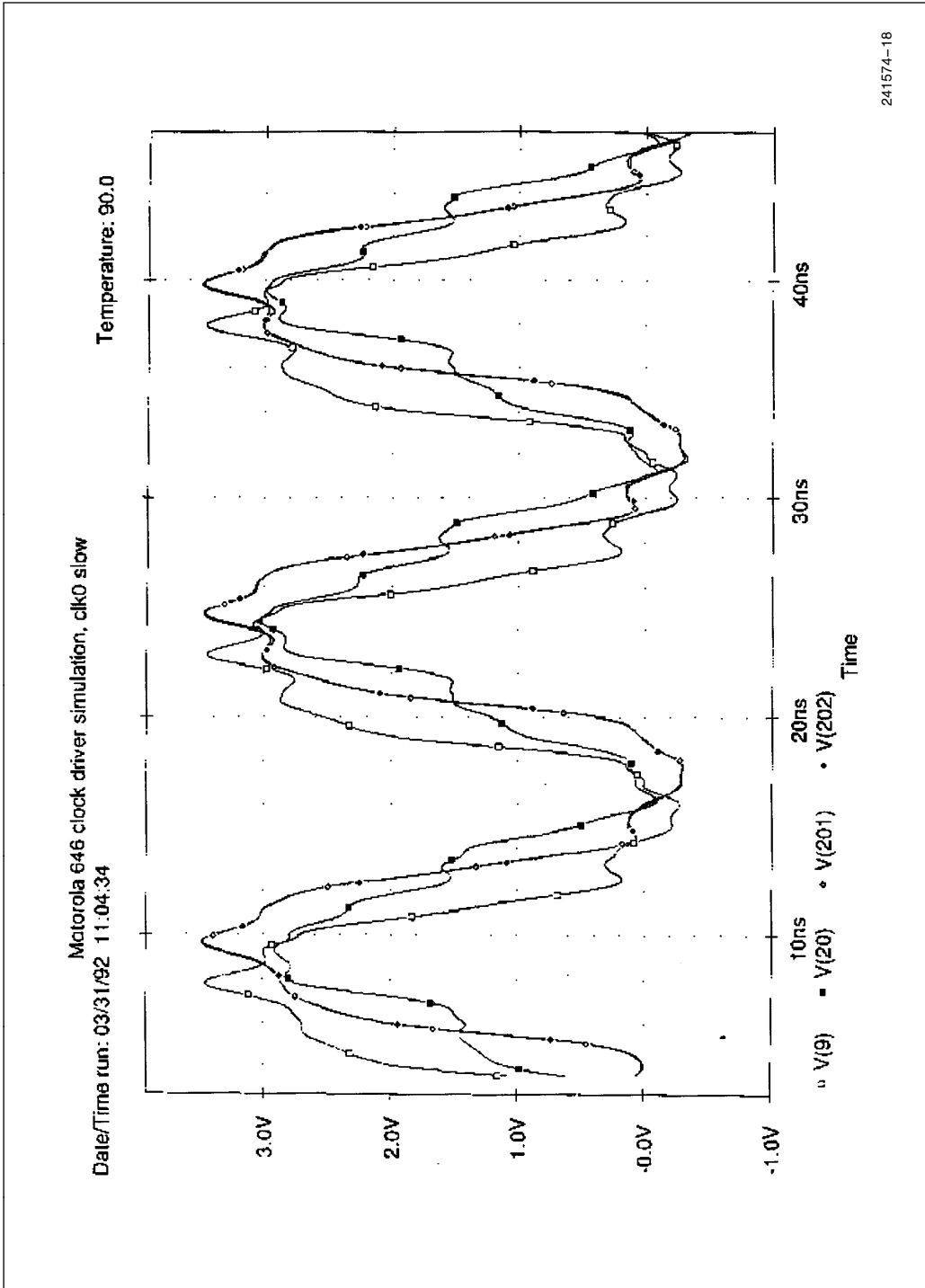

Figure 18. Motorola Waveform

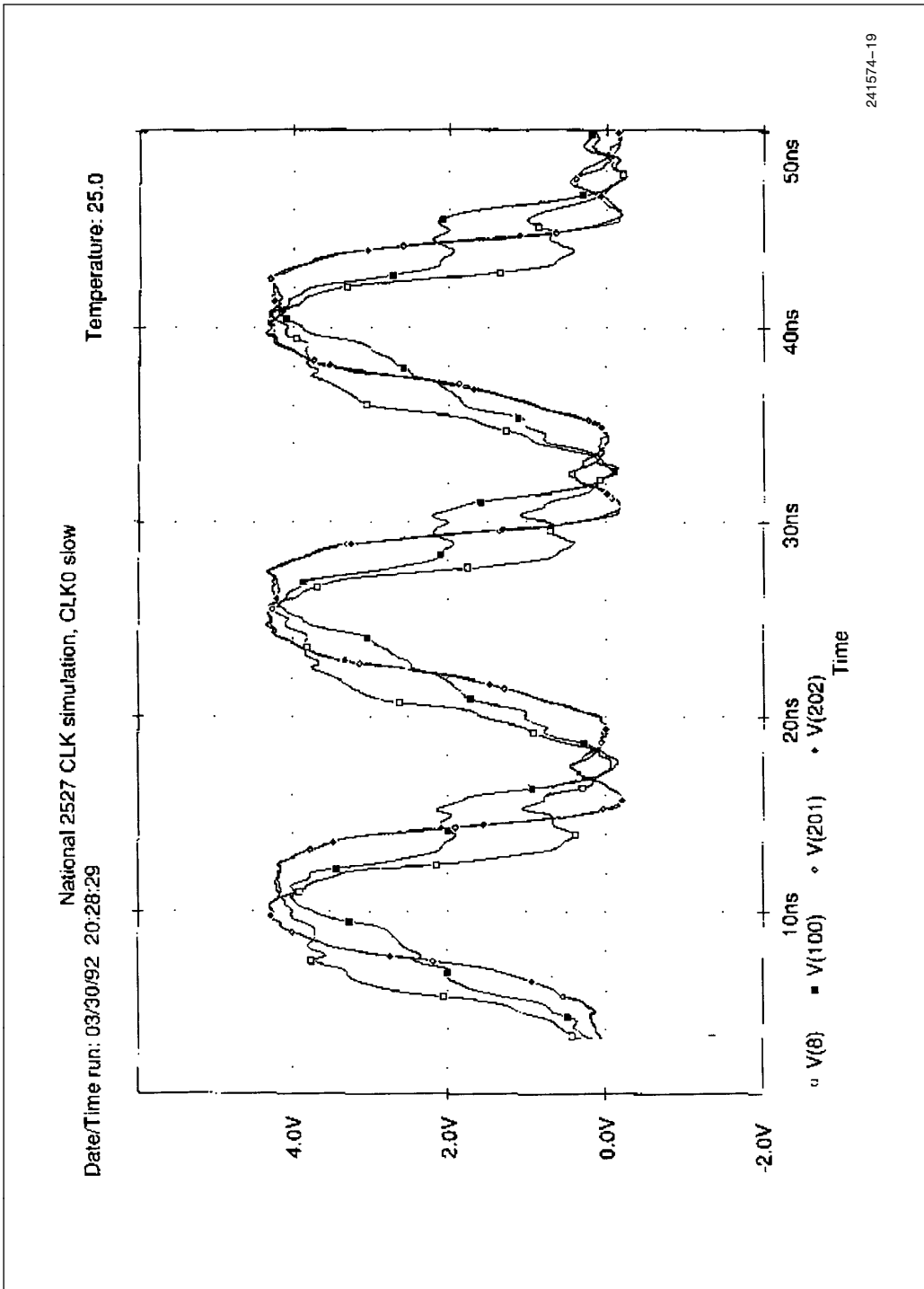
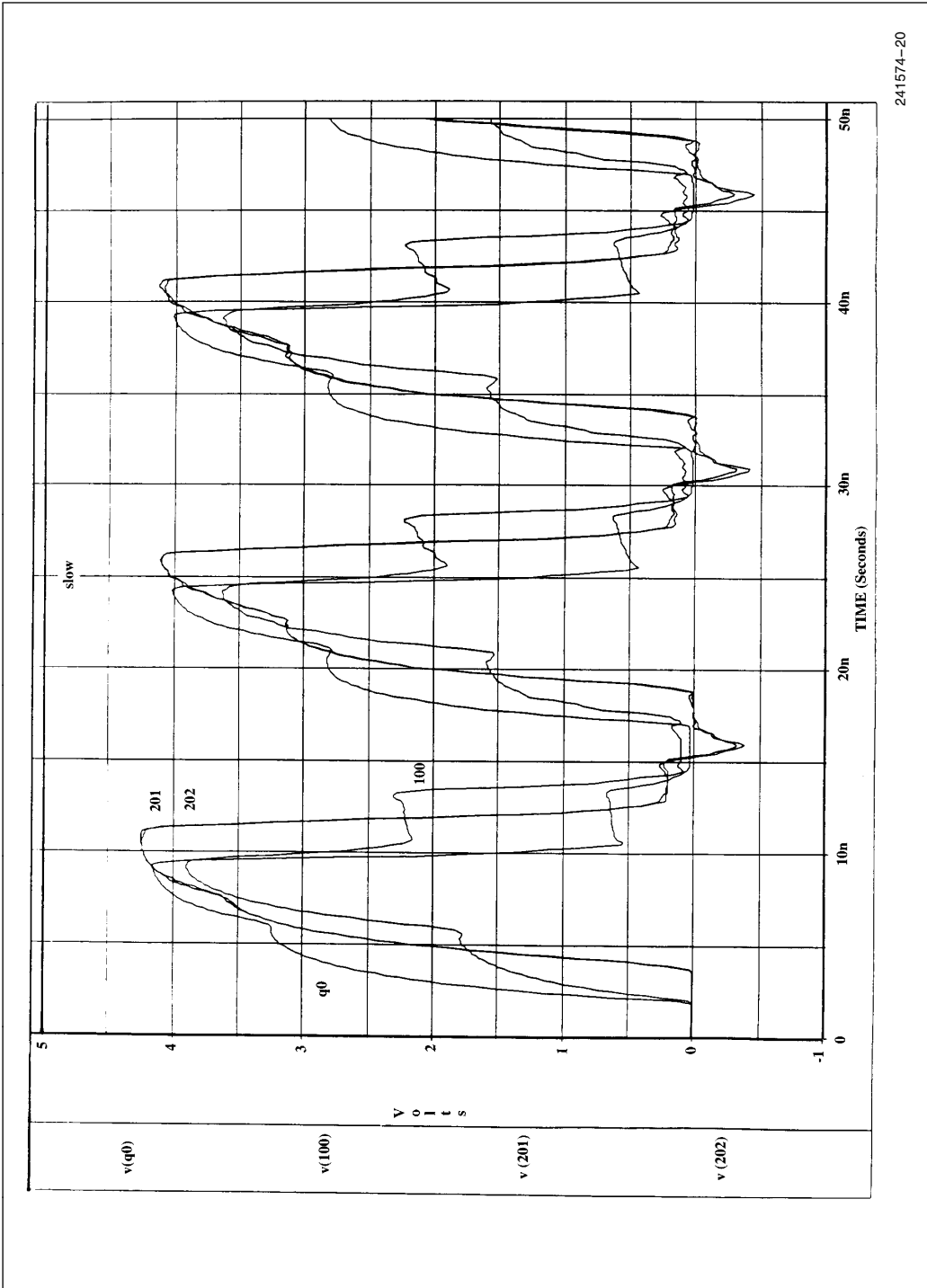

Figure 19. National Waveform





241574-20

Figure 20. Vitesse (Slow) Waveform

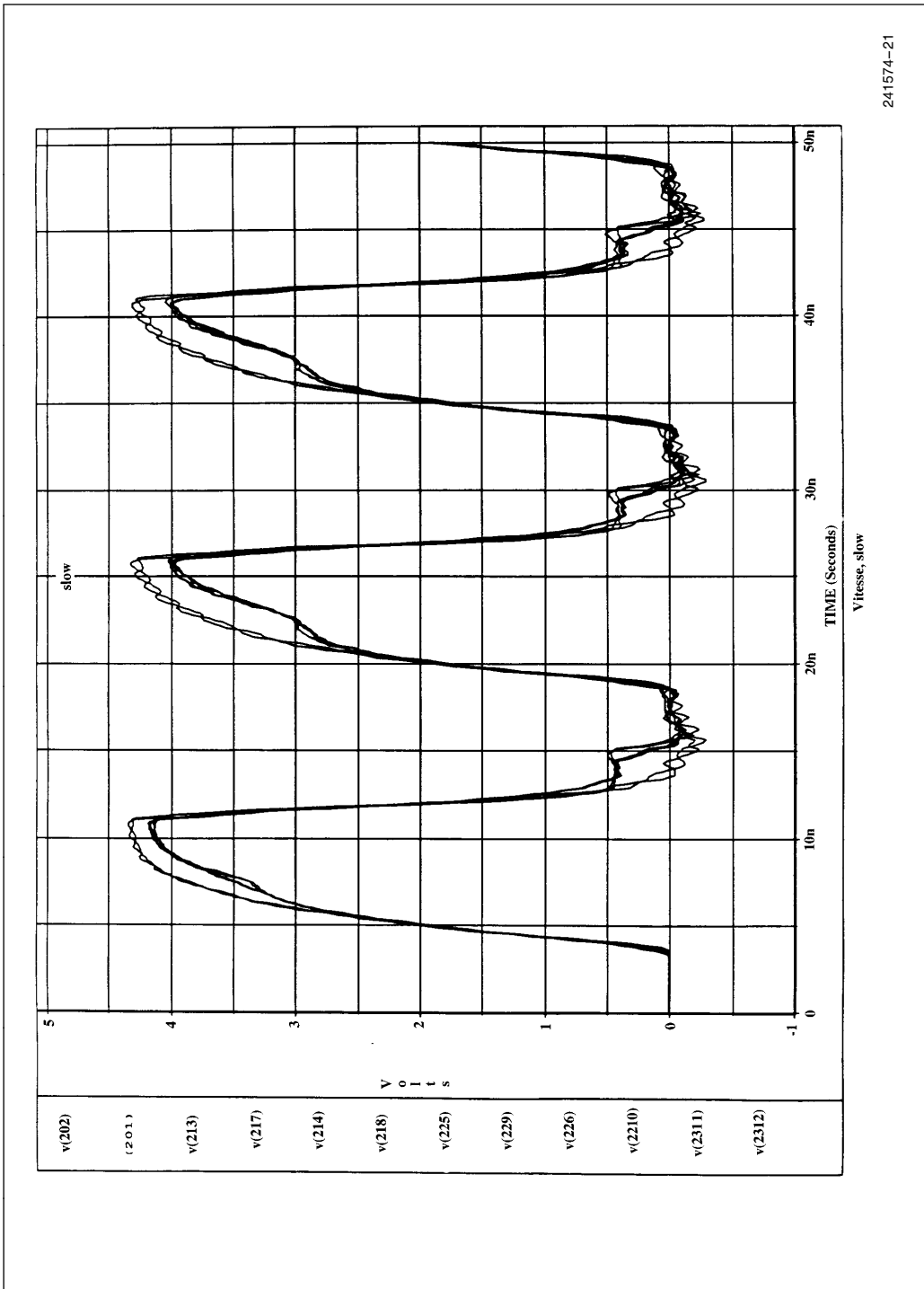

241574-21

Figure 21. Vitesse (Slow) Waveform (Continued)





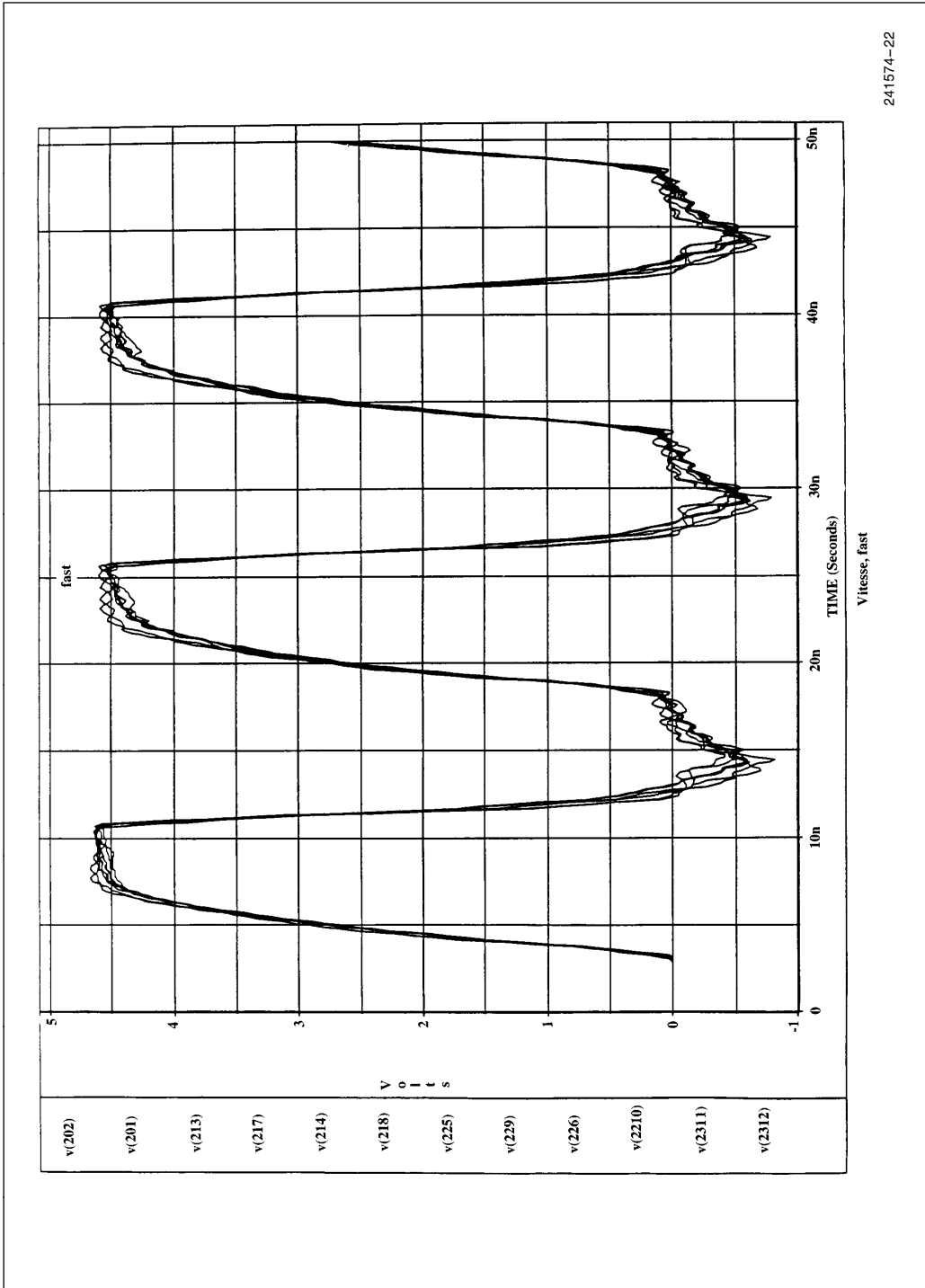

241574-22

Figure 22. Vitesse (Fast) Waveform

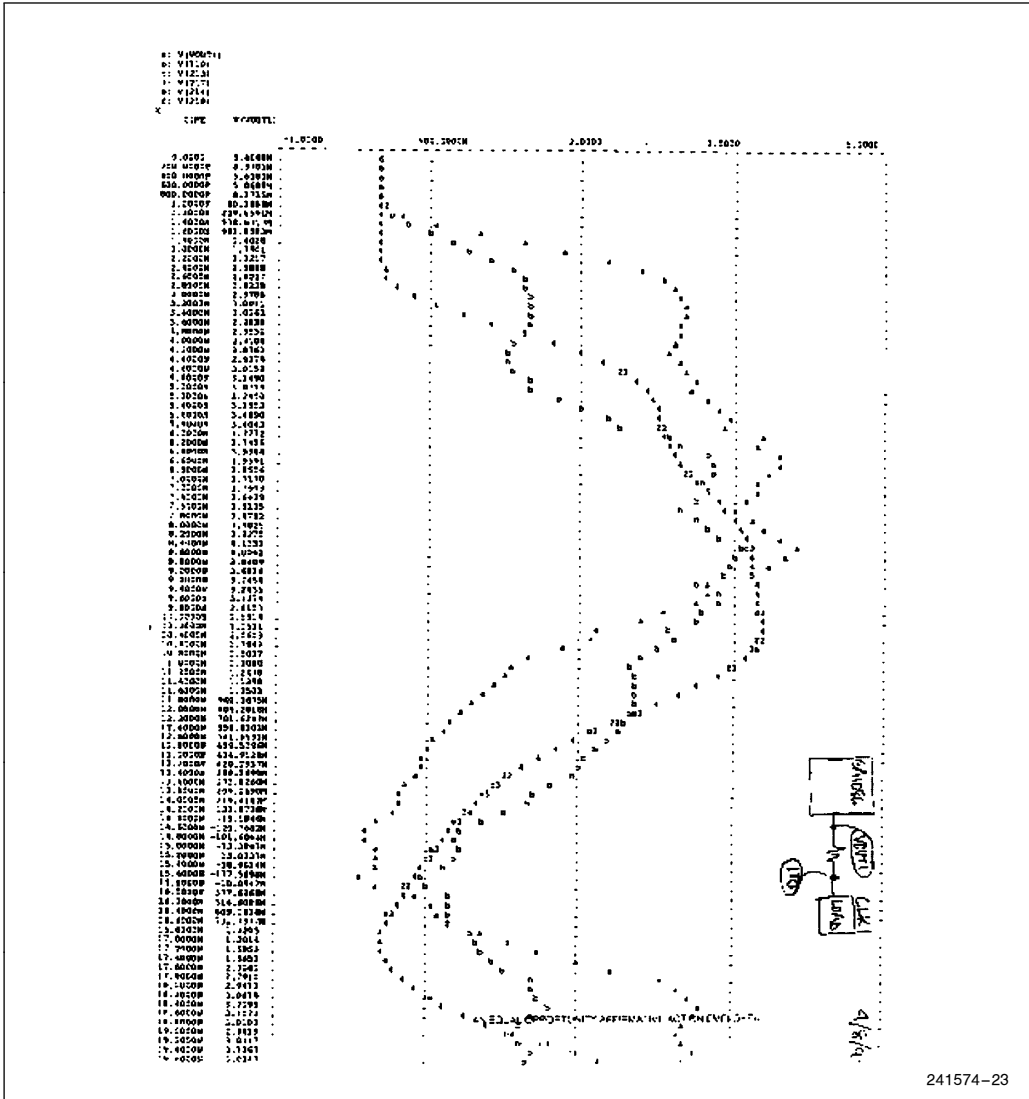

Figure 23. Triquant Waveform

241574-23



## 6.0 Pentium® PROCESSOR WITH 512K 82496/82491 SECOND LEVEL CACHE CLOCK DISTRIBUTION ISSUES

Clock distribution for 512K CPU-Cache chip set can be done in the same way as for the 256K chip set. Since there are more SRAM chips for the 512K cache, there are more loads that need clocking. Including parity, there are 18 82491s. Once again, the same principles apply. Keep the driver loading as close to balanced as possible. Tune traces and adjust termination resistance so that skew is minimized.

## 7.0 CLOCK DISTRIBUTION FOR THE Pentium® PROCESSOR WITH OTHER SECOND LEVEL CACHES

The Pentium processor can be used with cache configurations other than with the 82496 and 82491, as well as, without a second level cache. With other caches, the first thing that must be done is to decide how much skew is tolerable. Then, decide on which clock driver to use and carefully layout clock signals for distribution. If skew requirements do not exceed the CPU-Cache chip set requirements, the same drivers and the same distribution can be used. Design examples in Section 5.0 serve as a guide to how to distribute clocks for Pentium processor systems with tight skew.

If the Pentium processor is used without a second level cache, and only a small number of 66 MHz signals are needed, there are a few more options for clock drivers. For example, Motorola's 88915 has one 2x output that can run to maximum 70 MHz. Texas Instruments has the ABT337, 338, and 339 that can provide four copies of 66 MHz signals.

## 8.0 SUMMARY

At high speeds, clock synchronization becomes a difficult problem. Clock traces must be treated as transmission lines. Proper termination must be given to the lines to ensure good signal quality. The Pentium processor, with operating frequencies of 60 MHz and 66 MHz, has tight clock requirements. Together with the 82496 Cache Controller and 82491 Cache SRAM, the CPU-Cache chip set must be synchronized with minimal skew.

For the Pentium processor clocking, the most critical parameters are skew and rise and fall times. Depending

on the memory interface to the CPU-Cache chip set, there are many ways of generating multiple copies of clock signals.

Fully synchronous designs need to route 66 MHz only, but with minimal skew for all of them. Divided synchronous designs require both 66 MHz and 33 MHz signals. Asynchronous designs need to worry about the CPU-Cache chip set clock generation and distribution as well as the MBC.

Several clock drivers have been analyzed in detail with carefully tuned clock routing and the proper termination such that the clock signals transmitted to the Pentium processor, 82496, and 82491 meet all the timing requirements of the Intel chip set parts. Loading on a clock driver should be as balanced as possible. Clock traces should have equivalent length from driver output to load. The clock lines should be terminated properly to minimize reflections.

The same design principles used in the 256K CPU-Cache chip set clocking example can be applied to other CPU-cache configurations, or to a cacheless interface.

This application note has listed a number of devices from several different manufacturers. The purpose of this list is to supply a starting point for finding a clocking solution that meets each system's specific requirements. The lists provided are not meant as an endorsement or guarantee of the devices listed. In addition, these lists are not a complete listing of devices. These or other manufacturers may offer additional devices that meet the clock specifications for the Pentium processor.

## 9.0 REFERENCES

1. Intel Corporation, *Pentium® Processor Family Developer's Manual*, Order Number: 241563.
2. Intel Corporation, *Designing with the Pentium® Processor, 82496, and 82491 256K CPU-Cache Chip Set*, Order Number: 241576.
3. Jolly, Rich, *Clock Design in 50 MHz Intel486™ Systems*, Application Note AP-453, 1991, Intel Corporation, Santa Clara, CA.
4. Blood, William R., Jr., *MECL System Design Handbook*, 1988, Motorola Inc.
5. Hanke, Chris and Tharalson, Gary, *Low Skew Clock Drivers and their System Design Considerations*, Application Note AP-1091, Motorola Inc., 1990.

## APPENDIX A CLOCK DRIVER MANUFACTURERS

The following is a list of contacts for the clock driver manufacturers listed in this application note. It is not meant to be an exhaustive list of all possible solutions. It is meant as a starting point for system designers to assist in finding a clock solution that meets their system requirements.

### AMCC

#### *United States:*

Headquarters  
6195 Lusk Boulevard  
San Diego, CA 92121-2793  
Ph: 619-450-9333 or 800-PLL-AMCC (755-2622)  
FAX: 619-450-9885

#### *Europe:*

Amega Electronics  
Basingstoke, RG24OPF, U.K.  
Ph: 011/44-256-843166

#### *Japan:*

Teksel Co., Ltd.  
Kawasaki 213  
Tokyo, Japan  
Ph: 011/81-448127430

#### *Israel:*

EIM  
Petach Tiqva, Israel  
Ph: 011/972-3-9233257

### AT&T Microelectronics

AT&T Customer Response Center  
Ph: 800-372-2447 x773

Danny George  
555 Union Blvd.  
Allentown, PA 18103  
50N2G2100  
Ph: 215-439-6697

### Cypress

Sean Dingman  
3901 N. 1st St.  
San Jose, CA 95134  
408-943-2743

### ICS

Bruce Rogers  
Technical Marketing Manager  
2626 Van Buren Ave.  
P.O. Box 968  
Valley Forge, PA 19482  
215-666-1900

### Intel PLD BU International Contact List

#### *United States:*

John Van Sack  
Intel Corporation  
FM4-42  
1900 Prairie City Road  
Folsom, CA 95630  
Ph: (916) 356-3964  
FAX: (916) 356-6949

#### *Europe:*

Tony O'Sullivan  
Intel Corporation GmbH  
Dornacher Str. 1  
PostFach 213  
D-8016 FeldKirchen/Munchen  
Germany  
Ph: (49) 89/90992-340  
FAX: (49)89/9043948

#### *Japan:*

Norikazu Aoki  
5-6 Tokodia, Tsukuba-shi  
Ibaraki-Ken 300-26  
Japan  
Ph: 0298-47-0721  
FAX: 0298-47-8819

#### *APAC:*

Eric Chan  
Intel Technology SDN BHD  
Bayan Lepas Free Trade Zone,  
Box 121  
11900 Penang  
Malaysia  
Ph: 604-820-7271  
FAX: 604-836-405



**Motorola Inc.**

Todd Pearson  
Motorola Inc  
2200 W. Broadway Rd.  
Mesa, Arizona 85202  
USA  
Ph: (602) 962-3410

Masanori Matsubara  
Nippon Motorola LTD  
3-20-1, Minami-Azabu  
Minato Ku, Tokyo 106  
Japan  
Ph: 81-33-280-8383

Axel Krepil  
Motorola GMBH  
Schatzbogen 7  
8000 Munchen 81  
Germany  
Ph: 49-89-92103-167

Derek Leung  
Motorola Hong Kong LTD  
Silicon Harbour Center  
2 Dai King Street  
Taipo Industrial Estate  
Taipo N. T. Hong Kong  
Ph: 852-666-8194

**National Semiconductor**

National Semiconductor  
Santa Clara, CA  
Tony Ochoa  
Ph: 408-721-6804  
Ph: 800-272-9959

**Pioneer Semiconductor**

Joe Kraus  
2343 Bering Dr.  
San Jose, CA 95131  
Ph: 408-435-0800  
FAX: 408-435-1100

**Texas Instruments**

*United States:*

Steve Plote  
Program Manager  
CLOCK DRIVERS  
8330 LBJ Freeway, Center 3  
P.O. Box 655303  
Dallas, Texas 75265  
Ph: 214-997-5214

Brett Clark  
Applications Engineer  
Ph: 903-868-5836

*Japan:*

Mich Komatsu  
Texas Instruments Japan LTD.  
M.S. Shibaura Bldg. 13-23  
Shibaura 4-Chome  
Minato-ku Tokyo, 108 Japan  
Ph: 033-769-8717

*Asia Pacific Region:*

Eric Wey  
Texas Instruments Taiwan LTD.  
Taipei Branch  
10F Bank Tower, 205 Tung Hua N.  
Taipei, Taiwan ROC  
Ph: 886-2-713-9311

*Europe:*

Lothar Katz  
Texas Instruments  
8050 Freising, Fed. Rep. of Ger.  
Deutschland GMBH  
Haggertystr. 1  
Ph: 49-816-80314

**TriQuint Semiconductor**

*United States:*

Marketing, Sunil Sanghavi  
(408) 982-0900 x142, FAX (408) 982-0222  
Western Sales, Mark Wu  
(408) 982-0900 x113, FAX (408) 982-0222  
Central Sales, John Watson  
(214) 422-2532, FAX (214) 423-4947  
East Sales, Mike Zyla  
(215) 493-6944, FAX (215) 493-7418  
International, Mike Kilgore  
(503) 644-3535 x228, FAX (503) 644-3198





*Europe - GiGA A/S*

Fin Helmer, President  
45-4-343-1588, FAX 45-4-343-5967

*Japan - Japan Macnica Corp.*

Shin Ishikawa, Product Manager  
045-939-9140, FAX 045-939-6141

**Vitesse Semiconductor**

*United States:*

Corporate Headquarters  
Vitesse Semiconductor Corporation  
741 Calle Plano  
Camarillo, CA 93012  
Ph: 805-388-7501  
FAX: 805-388-7565

*Europe:*

Thomson Composants Micronodes  
Route Departementale 128 B.P. 48  
91401 Orsay Cedex France  
Ph: 33-1-60-19-7000  
FAX: 33-1-60-19-7140

*Japan:*

H.Y. Associates Co., LTD.  
3-1-10, Sekimachikita, Nerima-Ku  
Tokyo, 177 Japan  
Ph: 81-33-929-7111  
FAX: 81-33-928-0301

*Korea:*

Beaver International, Inc.  
3601 Deauville Court  
Calabasas, CA 91302  
Ph: 818-591-0356  
FAX: 818-591-0753

*Taiwan:*

Tamarack Microelectronics  
16 Fl., No. 1, Fu-Hsing N. Road  
Taipei, Taiwan, ROC  
Ph: 886-2-772-7400  
FAX: 886-2-776-0545

