



AP-731

**APPLICATION
NOTE**

**Understanding the Interrupt
Control Unit of the
80C186EC/80C188EC
Processor**

Sean Kohler
Application Engineer

Intel Corporation
5000 West Chandler Boulevard
Chandler, AZ 85226

March 13, 1996

Order Number: 272823-001

Information in this document is provided in connection with Intel products. Intel assumes no liability whatsoever, including infringement of any patent or copyright, for sale and use of Intel products except as provided in Intel's Terms and Conditions of Sale for such products.

Intel retains the right to make changes to these specifications at any time, without notice. Microprocessor products may have minor variations to this specification known as errata.

*Other brands and names are the property of their respective owners.

Contact your local Intel sales office or your distributor to obtain the latest specifications before placing your product order.

Copies of documents which have an ordering number and are referenced in this document, or other Intel literature, may be obtained from:

Intel Corporation
Literature Sales
P.O. Box 7641
Mt. Prospect, IL 60056-7641
or call 1-800-548-4725

Understanding the Interrupt Control Unit of the 80C186EC/80C188EC Processor

1.0 INTRODUCTION	1
2.0 OVERVIEW	2
3.0 INTERRUPT PROCESSING	2
4.0 82C59A PROGRAMMING	3
4.1 ICW Initialization Sequence	3
4.2 Initialization Command Words	5
4.2.1 ICW1 Beginning of Initialization Register	5
4.2.2 ICW1 Access	6
4.2.3 ICW2 Base Interrupt Type Register	6
4.2.4 ICW2 Access	6
4.2.5 ICW3 Cascaded Input Selection/Slave ID	7
4.2.6 ICW3 Access	7
4.2.7 ICW4 Special Fully Nested Mode/ Automatic End of Interrupt Mode Register	7
4.2.8 ICW4 Access	7
4.3 Operational Command Words	7
4.3.1 OCW1 Interrupt Mask Register	7
4.3.2 OCW1 Access	7
4.3.3 OCW2 Priority and EOI Register	7
4.3.4 OCW2 Access	8
4.3.5 OCW3 Special Mask Mode and Read Register Selection	8
4.3.6 OCW3 Access	8
5.0 RELATED INFORMATION	8
APPENDIX A Software Examples	A-1
A.1 Initialization Sequence and ISR Examples	A-1
A.2 ISR for Unexpected or Uninitialized Interrupts	A-9
FIGURES	
Figure 1. Interrupt Control Unit Block Diagram	1
Figure 2. Initialization Sequence of the ICW Registers	4
TABLES	
Table 1. A1 Address Line Connections	5
Table 2. Related Information	8
EXAMPLES	
Example A-1. Initialization Sequence and ISR Examples	A-1
Example A-2. ISR for Unexpected or Uninitialized Interrupts	A-9

1.0 INTRODUCTION

The Intel 186 processor core has two external interrupt sources; the Non-Maskable Interrupt (NMI) and a maskable interrupt source (INTR). The NMI input of the core is brought directly out to the NMI pin. For most embedded designs, a single maskable interrupt input is not sufficient. In order to expand the capabilities of the single maskable interrupt an interrupt controller is needed. Most of the 186 embedded processor proliferations use a proprietary interrupt controller to expand the number of available maskable interrupts.

Unlike other members of the 186 family of embedded microprocessors, the 80C186EC/80C188EC processor uses an 82C59A compatible interrupt control unit instead of a proprietary interrupt controller. (The 82C59A is an industry standard interrupt controller for embedded and PC-compatible solutions.) Two 82C59A compatible programmable interrupt controllers (PIC) are located on the 80C186EC/80C188EC processor die. One PIC is configured as the master while the other is configured as a slave. The slave is connected to IR7 of the master. See Figure 1.

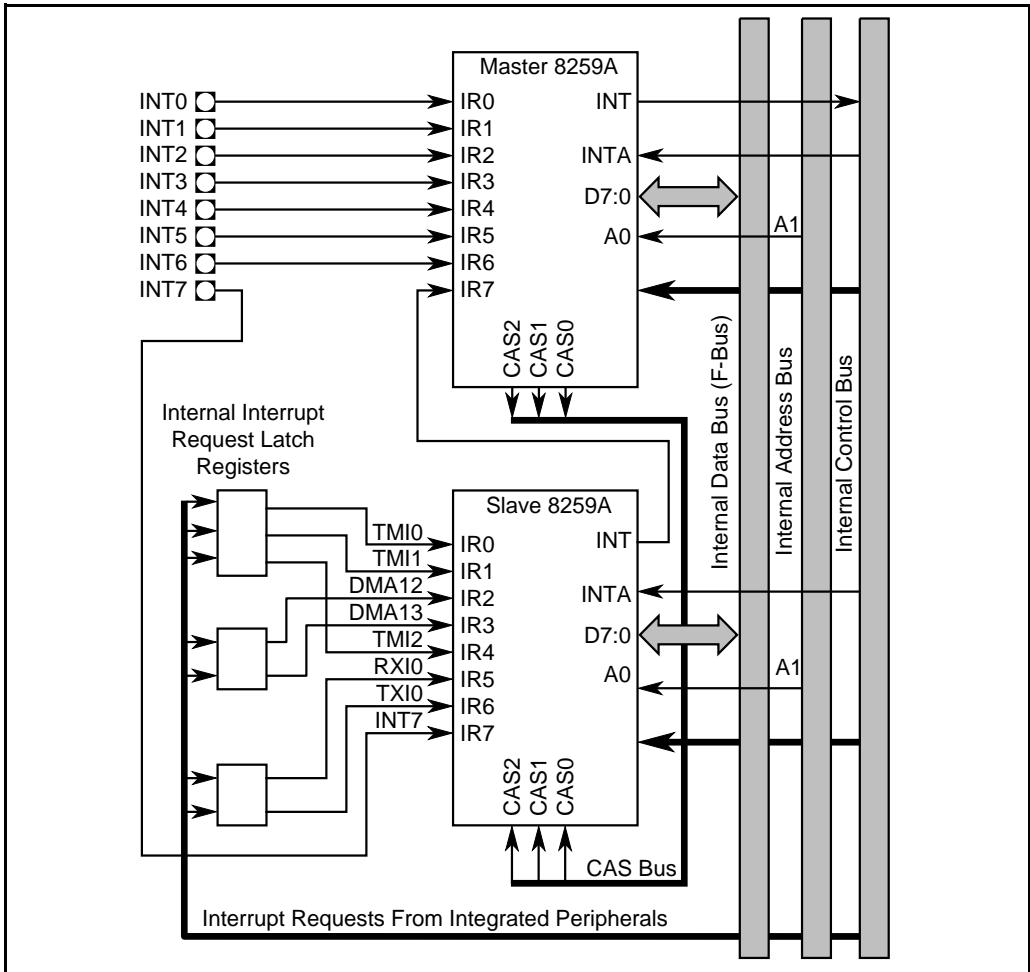

Figure 1. Interrupt Control Unit Block Diagram

The 82C59A has eight interrupt request lines. By cascading additional 82C59As, up to 64 interrupt request lines can be supported. Each cascaded 82C59A is called a slave; there can be only one master. The master PIC of the 80C186EC/80C188EC processor prioritizes interrupt requests from attached slaves and IR lines and presents requests, one at a time, to the single maskable interrupt line of the processor core.

This application note contains:

- A step-by-step description of the interrupt processing sequence.
- A description of subtleties associated with programming 82C59A registers.

This application note is meant to be used in conjunction with the 80C186EC/80C188EC Microprocessor User's Manual. Refer to the User's Manual for a complete explanation of the operation of 82C59A registers.

2.0 OVERVIEW

The 80C186EC/80C188EC processor can detect up to 256 different interrupts. Each interrupt is specified by its interrupt type ranging from 0 to 255. Each interrupt type has a corresponding interrupt vector, which is the interrupt type multiplied by 4. A vector is a double word pointer that points to the associated Interrupt Service Routine (ISR). An interrupt vector table in memory stores up to 256 interrupt vectors. The first word of the vector contains the offset of the associated ISR while the second word contains the segment. This makes each vector a total of 4 bytes. The interrupt vector table is located at the base of the processor's memory map, at 0000:0000. The interrupt vector table is 1 Kbyte in length (4 bytes multiplied by 256 types) and therefore goes up to 0000:03FF. Because of the location of the interrupt vectors, the lower 1 Kbyte of memory space should be reserved for interrupt vectors.

3.0 INTERRUPT PROCESSING

When an interrupt occurs, several steps are taken by the processor:

1. A partial machine status is saved/copied by pushing the Program Status Word (PSW) onto the stack.
2. The Trap Flag (TF) bit and the Interrupt Enable Flag (IF) bit are cleared in the PSW.

This prevents maskable interrupts or single step exceptions from interrupting the processor during the ISR. While in the ISR:

- To nest interrupts, set the IF bit in the PSW by issuing an STI instruction.
 - To use single stepping inside an ISR, push/copy the PSW onto the stack using the PUSHF instruction, modify the copy of the PSW on the stack to set the TF bit and then restore the PSW by popping the altered copy off of the stack using POPF.
3. The current CS and IP are pushed onto the stack.
 4. The interrupt controller passes the interrupt type to the processor. The processor multiplies the interrupt type by 4 to yield the base address of the associated interrupt vector. The processor reads a word from that address and loads it into the IP register. It then reads the next word at the interrupt vector address plus 2 and loads the value into the CS register. The processor begins executing code at the new location specified by CS and IP. This location is the ISR associated with the particular interrupt.

Upon completion of the ISR, the *programmer* must take several steps:

1. When the interrupt comes from one of the request lines of the PIC (not an exception), clear the In-Service bit for that interrupt source by issuing an end of interrupt command (EOI).

When the interrupt source is a slave PIC, clear the master's In-Service bit, then clear the slave's In-Service bit.

2. Issue an IRET instruction.

When an IRET instruction is executed, the *processor* takes the following steps:

1. Restores the CS and IP by popping the copies off the stack.
2. Restores the PSW by popping its copy off the stack.
3. Executes instructions at the address that the CS and IP point to (where the processor left off before the interrupt occurred).

The stack is used to store the pre-interrupt flag status and pre-interrupt program execution location. It is important to locate and allocate the stack such that data/code corruption does not occur during execution of single and nested interrupts.

4.0 82C59A PROGRAMMING

4.1 ICW Initialization Sequence

Before normal operation can begin, each 82C59A must be initialized by a sequence of two to four programming bytes called Initialization Command Words (ICWs). *After reset, the states of all the 82C59A registers are undefined.* The ICWs are used to set up the necessary conditions and modes for proper 82C59A operation. Minimum 82C59A initialization requires at least ICW1 and ICW2 to be configured. ICW3 and ICW4 are used only if designated in ICW1. The details of the function of each register are described in the *80C186EC/80C188EC Microprocessor User's Manual*.

NOTE:

The ICW initialization sequence is started (or restarted) at ICW1 by writing data to master port MPICP0 or slave port SPICP0 with the data bit position 4 set to a 1.

Figure 2 illustrates the initialization sequence of the ICW registers. *The sequence in which these registers are programmed is critical.*

Once the 82C59A is initialized, any changes to the ICWs are made by restarting the sequence. If the sequence is interrupted, the state machine can be reinitialized by writing to ICW1.

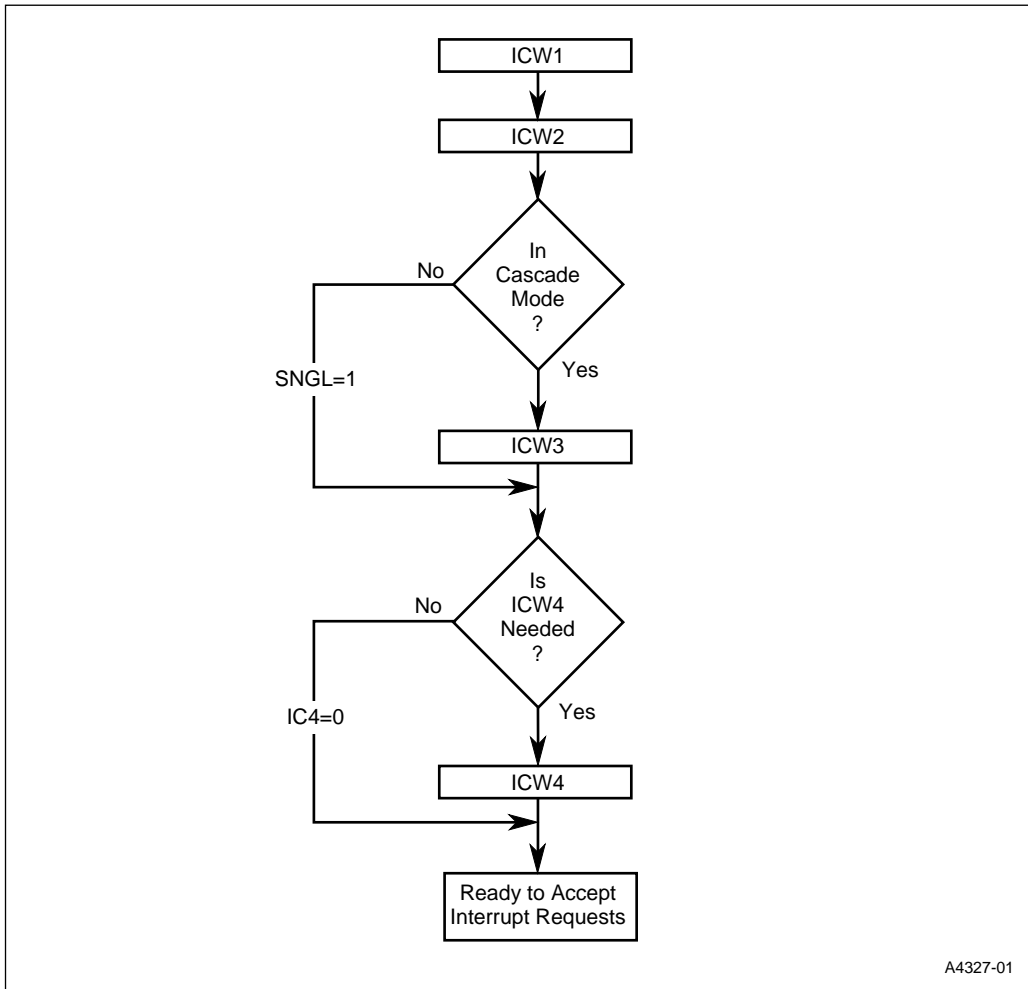

Figure 2. Initialization Sequence of the ICW Registers

A4327-01

Once the initialization sequence begins (ICW1 has been accessed), the 82C59A automatically performs the following events:

- The edge sense circuit is reset, which makes low to high transitions on the interrupt request (IR) line necessary for a valid interrupt.
- The interrupt mask register is cleared to allow interrupts on all IR lines to be processed. Since initialization is not yet completed, it is strongly recommended that all maskable interrupts be masked during initialization by issuing a CLI instruction. The CLI instruction masks off the single maskable interrupt source on the 8086 enhanced core. Since the 82C59A presents interrupt requests via the single maskable interrupt input, any request coming through any of the PICs will be masked when the CLI instruction is executed. Once initialization is complete, an STI instruction can be used to enable interrupts.
- IR7 input is assigned the highest priority.
- The slave mode address is set to 7.
- Special Mask Mode is cleared and Status Read is set to IRR.

NOTE:

For the 80C186EC processor, the SNGL bit should always be cleared (leading to initialization of ICW3) and the IC4 bit should always be set (leading to initialization of ICW4).

The complex initialization sequence exists because the original 8259 was designed with only one address line. Without the use of an initialization sequence (state machine), a device with only one address line would be able to access only two registers (ports). By implementing an initialization sequence, designers could keep the chip small and still access more than two registers (using only one address line).

Write accesses to the Initialization Command Words of the 82C59A are controlled by the following:

- The state of the A0 line of the 82C59A (which port being accessed)
- The data written to the register
- The sequence in which the data is written

The A0 line of the 82C59A is connected to the A1 address line of the 80C186EC/80C188EC processor. See Table 1.

Table 1. A1 Address Line Connections

Port Name	PCB Offset	A1 of Processor A0 of 82C59A
MPICP0	00	0
MPICP1	02	1
SPICP0	04	0
SPICP1	06	1

The first character of the port name indicates which internal 82C59A port is referenced: “M” indicates the Master PIC and “S” indicates the Slave.

4.2 Initialization Command Words

The Initialization Command Words (ICWs) are programmed in a sequential format and are used to set up the integrated interrupt controller to an initial state of operation. Typically, the ICW registers are programmed only once and are left untouched for the duration of the application. This section highlights some of the subtleties associated with the functionality of each register and with accessing each register.

4.2.1 ICW1 Beginning of Initialization Register

ICW1 is used to select level or edge sensitive triggering on the IRQ lines, the number of 82C59As in the system and to indicate whether or not the ICW4 register is used in the initialization sequence.

NOTE:

Mixed mode triggering is not possible. Either all of IR0 through IR7 is level triggered or edge triggered, but not both.

There are some subtle differences between edge and level sensitive interrupts. If an IRQ line is configured as level sensitive and is left asserted while it is serviced, the processor immediately vectors back into the ISR once the EOI is issued. Therefore, if configured as level sensitive, the IR line must be deasserted before issuing the EOI command inside the ISR. If the IR line is configured as edge sensitive, the processor will not vector back into the ISR if the IR line is kept asserted once the EOI has been issued. In order for another interrupt to occur on a edge sensitive IR line, the line must be brought to its inactive state for 100 ns to reset the edge detection circuitry.

4.2.2 ICW1 Access

ICW1 is a write-only register that is accessed through MPICP0 or SPICP0 with data bit position 4 set. See “ICW Initialization Sequence” on page 3 for more details.

4.2.3 ICW2 Base Interrupt Type Register

The data written to this register corresponds to the base interrupt type. The base interrupt type is synonymous with the interrupt type for IR0. Once the base type has been defined each subsequent IR_n line will have a $TYPE = BASE + n$. The interrupt vectors for each IR line will be at the location $TYPE*4$ in memory.

When an IR line is configured as a cascaded input, it still has an associated type (interrupt vector), but in most cases, it is not used.

There is a case in which an IR line configured as Cascade Mode still uses its corresponding interrupt vector. This special case exists when IR7 is configured for Cascade mode and it is also used for spurious interrupt detection. If any IR line is asserted and is deasserted before the falling edge of the first interrupt acknowledge pulse, then a special interrupt called a “spurious interrupt” is generated. The 82C59A detects these spurious interrupts when an IR line is asserted in this manner, and generates an interrupt of type IR7. The only difference between a true IR7 interrupt and an interrupt caused by a spurious interrupt detection is the fact that when a spurious interrupt is acknowledged, the In-Service bit for IR7 is never set. Spurious interrupt detection is useful in noisy environments where unwanted glitches might be interpreted as valid interrupt assertions.

If IR7 is configured for Cascade mode then an interrupt of type IR7 can occur if a spurious interrupt was detected on one of the IR_n lines of the PIC. If configured for Cascade

mode and a spurious interrupt does occur, a typical IR7 ISR (spurious interrupt ISR) simply returns control back to the main program by issuing an IRET instruction. See Appendix A for details

If IR7 is being used and it is not configured in Cascade Mode, then there are two possibilities for an interrupt of type IR7 to occur:

- A valid IR7 interrupt occurred
- A spurious interrupt was detected on one of the IR_n lines of the PIC

If not configured for Cascade mode, once inside the IR7 ISR, software must examine the In-Service register to determine what event caused the processor to enter the ISR. If the In-Service bit for IR7 is set, then a valid IR7 interrupt occurred. If the In-Service bit is not set, then a spurious interrupt must have occurred on one of the eight IR lines of the PIC. Once the software has determined that it is inside the IR7 ISR because of a spurious interrupt, most ISRs just issue an IRET instruction to return control back to the main program. If the processor is inside the IR7 ISR because of a valid interrupt, the interrupt is serviced, its In-Service bit is cleared by issuing a End of Interrupt (EOI) then finally the ISR is completed and control returned back to the main program by issuing a IRET instruction. See Appendix A for an example.

4.2.4 ICW2 Access

ICW2 is a write-only register which is accessed by a write to MPICP1 or SPICP1 immediately after ICW1 has been configured. See “ICW Initialization Sequence” for more details.

4.2.5 ICW3 Cascaded Input Selection/Slave ID

ICW3 of the master is used to select whether or not a slave will be connected to the associated IR line.

ICW3 of a slave is used to set the associated slave ID. The slave ID should match the IR line number of the master that it is connected to.

NOTE:

Special precautions must be taken when connecting a slave to IR0 of a master 82C59A module. A slave programmed for an ID of zero will be active for both interrupts that it has requested, as well as for uncascaded master interrupts; uncascaded interrupts leave the cascade bus (CAS2:0) lines low. If this situation occurs there will be contention on the data bus, since both the master and the slave attempt to drive the interrupt type on the data bus. Never cascade a slave 82C59A module to IR0 of a master module unless IR0 is the last available uncascaded input (i.e., the system is fully cascaded with eight slave 82C59A modules).

4.2.6 ICW3 Access

ICW3 is a write-only register. If the SNGL bit of ICW1 was cleared during the initialization sequence, ICW3 can be accessed by a write to MPCIP1 or SPCIP1 immediately after ICW2 has been initialized. See “ICW Initialization Sequence” for more details.

4.2.7 ICW4 Special Fully Nested Mode/Automatic End of Interrupt Mode Register

ICW4 is a write-only register. Special Fully Nested (SFN) Mode and Automatic End of Interrupt (AEOI) Mode are selected using ICW4.

4.2.8 ICW4 Access

ICW4 is accessed by a write to MPICP1 or SPICP1 provided that the IC4 bit was set in ICW1 during the initialization sequence. See “ICW Initialization Sequence” for more details.

4.3 Operational Command Words

Once the 82C59A has been initialized using the ICWs, the Operational Command Words (OCWs) can be used to modify priority schemes, End of Interrupt (EOI) configurations and interrupt masking.

Three OCWs are available for programming but, unlike the ICWs, the OCW registers can be accessed in any order. These registers can be accessed whenever the programmer desires, provided that the ICWs have been previously initialized. Although there is no accessing sequence to the OCWs, accessing each OCW and accompanying register (described later) is not intuitive. A detailed description of the OCW registers is given in the *80C186EC/80C188EC Microprocessor User's Manual*. This section highlights some of the subtleties associated with the function of each register and with accessing each register.

4.3.1 OCW1 Interrupt Mask Register

OCW1 is the interrupt mask register. Setting a bit in the mask register disables the corresponding interrupt request on the associated IR line.

It is important to note that if the IR line is asserted while it is masked, the associated interrupt request bit will be set, but the interrupt will never be presented to the processor core because it is masked. If an IR line is unmasked while the interrupt request bit is set, the interrupt request will be presented to the processor core. Therefore, it is important to clear the associated interrupt request bit when masking and unmasking interrupts. The interrupt request bit can be cleared by reading the interrupt request register (see “OCW3 Special Mask Mode and Read Register Selection”).

4.3.2 OCW1 Access

OCW1 is accessed by read or writes to SPICP1 or MPICP1 provided that the ICW initialization sequence has been completed.

4.3.3 OCW2 Priority and EOI Register

OCW2 is used to set interrupt priority schemes and various End of Interrupt (EOI) configurations. A detailed description of its operation is in the *80C186EC/80C188EC Microprocessor User's Manual*.

4.3.4 OCW2 Access

OCW2 is a write only register that is accessed by writes to MPICP0 or SPICP0 with data bit position 3 and 4 cleared provided that the ICW initialization sequence has been completed.

4.3.5 OCW3 Special Mask Mode and Read Register Selection

OCW3 is used to control Special Mask Mode, Poll Mode and read register selection. A detailed explanation is given in the *80C186EC/80C188EC Microprocessor User's Manual*.

Setting the ERR bit in conjunction with either clearing or setting the RSEL bit determines which register is accessed through a read cycle to the MPICP0 or SPICP0 port.

- If the OCW3 register is written to and the RSEL bit is set in conjunction with the ERR bit, then a read to either MPICP0 or SPICP0 will be a read to the In-Service register.
- If the OCW3 register is written to and the RSEL bit is cleared in conjunction with the ERR bit, then a read to either MPICP0 or SPICP0 will be a read to the Interrupt Request register.

The RSEL bit can only be modified when the ERR bit is set.

The In-Service register is an 8-bit register containing the priority levels that are being serviced. The In-Service register is updated when an End of Interrupt (EOI) command is issued. Once the In-Service bit is set, assertions to the corresponding IR line will be ignored until it is cleared (by issuing an EOI).

The Interrupt Request register is an 8-bit register containing the priority of the interrupts waiting to be acknowledged. The highest request level is reset from the Interrupt Request register when an interrupt is acknowledged.

4.3.6 OCW3 Access

OCW3 is a write only register that is accessed by writing to MPICP0 or SPICP0 with data bit position 3 set and data bit positions 4 and 7 cleared.

5.0 RELATED INFORMATION

Intel offers a variety of information through the World Wide Web at <http://www.intel.com>.

To order printed Intel literature, contact:

Intel Corporation
Literature Fulfillment
P.O. Box 7641
Mt. Prospect, IL 60056-7641
1-800-548-4725

Table 2. Related Information

Document Name	Order #
<i>80C186EC/80C188EC Microprocessor User's Manual</i>	272047
<i>Embedded Microprocessors Databook</i> see the <i>80C186EC/80C188EC and 80L186EC/80L188EC 16-Bit High-Integration Embedded Processors</i> datasheet	272396
<i>Peripheral Components Databook</i> see the <i>82C59A-2 CHMOS Programmable Interrupt Controller</i> datasheet	296467

APPENDIX A

Software Examples

A.1 Initialization Sequence and ISR Examples

This software example illustrates interrupt vector initialization, basic interrupt controller initialization sequence and simple interrupt service routines. This software was assembled using Intel ASM86 and was tested using the Intel EV80C186EC evaluation board REV 1.1.

Example A-1. Initialization Sequence and ISR Examples (Sheet 1 of 8)

```

$ TITLE (82C59 Programming Example)
$ MOD186

NAME ICU_DEMO

$INCLUDE (C:\EV186EC\ECPCB.INC)
;INCLUDE PERIPHERAL CONTROL BLOCK REGISTER MAP

_7SEG1          EQU      1000H    ;7 SEGMENT #1 I/O ADDRESS
_7SEG2          EQU      1010H    ;7 SEGMENT #2 I/O ADDRESS

ZERO            EQU      03FH     ;BIT MAPS FOR 7 SEG DISPLAY
ONE             EQU      06H
TWO            EQU      05BH
THREE          EQU      04FH
FOUR           EQU      066H
FIVE           EQU      06DH
SIX            EQU      07CH
SEVEN          EQU      07H
PATTERN1       EQU      064H     ;IDENTIFIES SPURIOUS INTERRUPT ON MASTER
PATTERN2       EQU      052H     ;IDENTIFIES SPURIOUS INTERRUPT ON SLAVE

MASTER_BASE_TYPE EQU      96      ;TYPE*4 = BASE ADDR OF MASTER
SLAVE_BASE_TYPE EQU      104     ;TYPE*4 = BASE ADDR OF SLAVE

;SEE FIGURE 8-1 OF THE 80C186EC/80C188EC USER'S MANUAL

INT0_TYPE      EQU      MASTER_BASE_TYPE
INT1_TYPE      EQU      MASTER_BASE_TYPE + 1
INT2_TYPE      EQU      MASTER_BASE_TYPE + 2
INT3_TYPE      EQU      MASTER_BASE_TYPE + 3
INT4_TYPE      EQU      MASTER_BASE_TYPE + 4
INT5_TYPE      EQU      MASTER_BASE_TYPE + 5
INT6_TYPE      EQU      MASTER_BASE_TYPE + 6
INT7_TYPE      EQU      SLAVE_BASE_TYPE + 7
SPM_TYPE       EQU      MASTER_BASE_TYPE + 7

```

Example A-1. Initialization Sequence and ISR Examples (Sheet 2 of 8)

```

;*****
;CODE SEGMENT AT LOCATION 1000H WHICH IS IN THE SRAM OF THE EV80C186EC EVALUATION
;BOARD
;*****

EC_CODE SEGMENT AT 0100H          ;PUT CODE IN SRAM OF EVALBOARD
    ASSUME CS:EC_CODE

MAIN:  CLI                        ;DISABLE INTERRUPTS

        CALL CLR_LEDS             ;CLEAR 7SEG DISPLAYS
        CALL SETVECT             ;INITIALIZE INTERRUPT VECTORS
        CALL INIT_ICU            ;INITIALIZE INTERRUPT CONTROL UNIT
        STI                      ;ENABLE INTERRUPTS

        JMP $                    ;WAIT FOR INTERRUPTS

;*****
;PROCEDURE: SETVECT
;
;THIS PROCEDURE INITIALIZES THE INTERRUPT VECTOR TABLE FOR EXTERNAL
;INTERRUPTS INTO-7 AND ALSO INITIALIZES THE INTERRUPT VECTORS FOR SPURIOUS
;INTERRUPT DETECTION
;*****
SETVECT PROC

        XOR AX, AX                ;CLEAR ACCUMULATOR
        MOV DS, AX               ;CLEAR DATA SEGMENT

        ;SETUP INT0 INTERRUPT VECTOR

        MOV DI, INT0_TYPE*4      ;MOVE BASE ADDRESS OF INT0 VECTOR IN TO DI
        MOV WORD PTR DS:[DI], OFFSET INT0_ISR
        MOV WORD PTR DS:[DI+2], SEG INT0_ISR

        ;SETUP INT1 INTERRUPT VECTOR

        MOV DI, INT1_TYPE*4      ;MOVE BASE ADDRESS OF INT1 VECTOR IN TO DI
        MOV WORD PTR DS:[DI], OFFSET INT1_ISR
        MOV WORD PTR DS:[DI+2], SEG INT1_ISR

        ;SETUP INT2 INTERRUPT VECTOR

        MOV DI, INT2_TYPE*4      ;MOVE BASE ADDRESS OF INT2 VECTOR IN TO DI
        MOV WORD PTR DS:[DI], OFFSET INT2_ISR
        MOV WORD PTR DS:[DI+2], SEG INT2_ISR

        ;SETUP INT3 INTERRUPT VECTOR

        MOV DI, INT3_TYPE*4      ;MOVE BASE ADDRESS OF INT3 VECTOR IN TO DI
        MOV WORD PTR DS:[DI], OFFSET INT3_ISR
        MOV WORD PTR DS:[DI+2], SEG INT3_ISR

        ;SETUP INT4 INTERRUPT VECTOR

```

Example A-1. Initialization Sequence and ISR Examples (Sheet 3 of 8)

```

MOV DI, INT4_TYPE*4      ;MOVE BASE ADDRESS OF INT4 VECTOR IN TO DI
MOV WORD PTR DS:[DI], OFFSET INT4_ISR
MOV WORD PTR DS:[DI+2], SEG INT4_ISR

;SETUP INT5 INTERRUPT VECTOR

MOV DI, INT5_TYPE*4      ;MOVE BASE ADDRESS OF INT5 VECTOR IN TO DI
MOV WORD PTR DS:[DI], OFFSET INT5_ISR
MOV WORD PTR DS:[DI+2], SEG INT5_ISR

;SETUP INT6 INTERRUPT VECTOR

MOV DI, INT6_TYPE*4      ;MOVE BASE ADDRESS OF INT6 VECTOR IN TO DI
MOV WORD PTR DS:[DI], OFFSET INT6_ISR
MOV WORD PTR DS:[DI+2], SEG INT6_ISR

;SETUP INT7 INTERRUPT VECTOR (ALSO THE INTERRUPT VECTOR FOR SPURIOUS
;INTERRUPT DETECTION FOR THE SLAVE)

MOV DI, INT7_TYPE*4      ;MOVE BASE ADDRESS OF INT7 VECTOR IN TO DI
MOV WORD PTR DS:[DI], OFFSET INT7_ISR
MOV WORD PTR DS:[DI+2], SEG INT7_ISR

;SETUP SPURIOUS INTERRUPT VECTOR FOR MASTER

MOV DI, SPM_TYPE*4       ;MOVE BASE ADDRESS OF IR7 OF MASTER VECTOR TO DI
MOV WORD PTR DS:[DI], OFFSET SPM_ISR
MOV WORD PTR DS:[DI+2], SEG SPM_ISR

RET
SETVECT ENDP

;+++++
;INTERRUPT SERVICE ROUTINE: INT0_ISR
;
;THIS PROCEDURE WILL DISPLAY A 'O' ON THE 7 SEGMENT DISPLAY IF INT0 WAS ASSERTED
;+++++
INT0_ISR PROC

    MOV DX, _7SEG1        ;DISPLAY 'O' ON 7 SEGMENT DISPLAY
    MOV AL, ZERO
    OUT DX, AL

    MOV DX, MPIC0         ;CLEAR IN-SERVICE BIT BY ISSUING EOI
    MOV AL, 20H
    OUT DX, AL

    IRET
INT0_ISR ENDP
  
```

Example A-1. Initialization Sequence and ISR Examples (Sheet 4 of 8)

```

;*****
;INTERRUPT SERVICE ROUTINE: INT1_ISR
;
;THIS PROCEDURE WILL DISPLAY A '1' ON THE 7 SEGMENT DISPLAY IF INT1 WAS ASSERTED
;*****
INT1_ISR PROC

    MOV DX, _7SEG1          ;DISPLAY '1' ON 7 SEGMENT DISPLAY
    MOV AL, ONE
    OUT DX, AL

    MOV DX, MPICP0         ;CLEAR IN-SERVICE BIT BY ISSUING EOI
    MOV AL, 20H
    OUT DX, AL

    IRET
INT1_ISR ENDP

;*****
;INTERRUPT SERVICE ROUTINE: INT2_ISR
;
;THIS PROCEDURE WILL DISPLAY A '2' ON THE 7 SEGMENT DISPLAY IF INT2 WAS ASSERTED
;*****
INT2_ISR PROC

    MOV DX, _7SEG1          ;DISPLAY '2' ON 7 SEGMENT DISPLAY
    MOV AL, TWO
    OUT DX, AL

    MOV DX, MPICP0         ;CLEAR IN-SERVICE BIT BY ISSUING EOI
    MOV AL, 20H
    OUT DX, AL

    IRET
INT2_ISR ENDP

;*****
;INTERRUPT SERVICE ROUTINE: INT3_ISR
;
;THIS PROCEDURE WILL DISPLAY A '3' ON THE 7 SEGMENT DISPLAY IF INT3 WAS ASSERTED
;*****
INT3_ISR PROC

    MOV DX, _7SEG1          ;DISPLAY '3' ON 7 SEGMENT DISPLAY
    MOV AL, THREE
    OUT DX, AL

    MOV DX, MPICP0         ;CLEAR IN-SERVICE BIT BY ISSUING EOI
    MOV AL, 20H
    OUT DX, AL

    IRET
INT3_ISR ENDP

```

Example A-1. Initialization Sequence and ISR Examples (Sheet 5 of 8)

```

;+++++
;INTERRUPT SERVICE ROUTINE: INT4_ISR
;
;THIS PROCEDURE WILL DISPLAY A '4' ON THE 7 SEGMENT DISPLAY IF INT4 WAS ASSERTED
;+++++
INT4_ISR PROC

        MOV DX, _7SEG1           ;DISPLAY '4' ON 7 SEGMENT DISPLAY
        MOV AL, FOUR
        OUT DX, AL

        MOV DX, MPICP0          ;CLEAR IN-SERVICE BIT BY ISSUING EOI
        MOV AL, 20H
        OUT DX, AL

        IRET
INT4_ISR ENDP

;+++++
;INTERRUPT SERVICE ROUTINE: INT5_ISR
;
;THIS PROCEDURE WILL DISPLAY A '5' ON THE 7 SEGMENT DISPLAY IF INT5 WAS ASSERTED
;+++++
INT5_ISR PROC

        MOV DX, _7SEG1           ;DISPLAY '5' ON 7 SEGMENT DISPLAY
        MOV AL, FIVE
        OUT DX, AL

        MOV DX, MPICP0          ;CLEAR IN-SERVICE BIT BY ISSUING EOI
        MOV AL, 20H
        OUT DX, AL

        IRET
INT5_ISR ENDP

;+++++
;INTERRUPT SERVICE ROUTINE: INT6_ISR
;
;THIS PROCEDURE WILL DISPLAY A '6' ON THE 7 SEGMENT DISPLAY IF INT6 WAS ASSERTED
;+++++
INT6_ISR PROC

        MOV DX, _7SEG1           ;DISPLAY '6' ON 7 SEGMENT DISPLAY
        MOV AL, SIX
        OUT DX, AL

        MOV DX, MPICP0          ;CLEAR IN-SERVICE BIT BY ISSUING EOI
        MOV AL, 20H
        OUT DX, AL

        IRET
INT6_ISR ENDP
  
```

Example A-1. Initialization Sequence and ISR Examples (Sheet 6 of 8)

```

;*****
;INTERRUPT SERVICE ROUTINE: INT7_ISR
;
;THIS PROCEDURE WILL DISPLAY A '7' ON THE 7 SEGMENT DISPLAY IF INT7 WAS ASSERTED
;OR WILL DISPLAY PATTERN2 IF A SPURIOUS INTERRUPT WAS DETECTED ON THE SLAVE
;*****
INT7_ISR PROC

        MOV DX, SPICP0          ;PREPARE TO READ IN-SERVICE REGISTER
        MOV AL, 0BH
        OUT DX, AL

        IN AL, DX              ;READ FROM IN-SERVICE REGISTER TO DETERMINE
                               ;IF VALID INTERRUPT OR SPURIOUS INTERRUPT

        CMP AL, 80H           ;CHECK TO SEE IF SPURIOUS OR NOT (10000000)=IR7
        JZ IR7                ;JUMP IF INTERRUPT WAS IR7 ASSERTION

        MOV DX, _7SEG1        ;DISPLAY PATTERN2 ON 7 SEGMENT DISPLAY
        MOV AL, PATTERN2      ;TO ILLUSTRATE SPURIOUS INTERRUPT HAS
        OUT DX, AL            ;OCCURED ON SLAVE

        JMP DONE

IR7:    MOV DX, _7SEG1        ;DISPLAY '7' ON 7 SEGMENT DISPLAY
        MOV AL, SEVEN
        OUT DX, AL

        MOV DX, SPICP0        ;CLEAR IN-SERVICE BIT OF SLAVE BY ISSUING EOI
        MOV AL, 20H
        OUT DX, AL

DONE:   MOV DX, MPICP0        ;CLEAR IN-SERVICE BIT OF MASTER BY ISSUING EOI
        MOV AL, 20H
        OUT DX, AL

        IRET
INT7_ISR ENDP

;*****
;INTERRUPT SERVICE ROUTINE: SPM_ISR
;
;THIS PROCEDURE WILL DISPLAY PATTERN1 ON THE 7 SEGMENT DISPLAY IF SPURIOUS
;INTERRUPT WAS DETECTED ON THE MASTER
;*****
SPM_ISR PROC

        MOV DX, _7SEG1        ;DISPLAY PATTERN1 ON 7 SEGMENT DISPLAY
        MOV AL, PATTERN1      ;TO ILLUSTRATE SPURIOUS INTERRUPT HAS
        OUT DX, AL            ;OCCURED ON MASTER PIC

        IRET
SPM_ISR ENDP

```

Example A-1. Initialization Sequence and ISR Examples (Sheet 7 of 8)

```

;+++++
;PROCEDURE: CLR_LEDS
;THIS PROCEDURE SIMPLY TURNS OFF ALL OF THE SEGMENTS THE 7 SEGMENT DISPLAY
;+++++
CLR_LEDS PROC
    MOV DX, _7SEG1
    XOR AL, AL
    OUT DX, AL

    MOV DX, _7SEG2
    OUT DX, AL

    RET
CLR_LEDS ENDP

;+++++
;PROCEDURE: INIT_ICU
;THIS PROCEDURE INITIALIZES THE INTERNAL MASTER AND SLAVE 82C59 OF THE
;80C186EC PROCESSOR
;+++++
INIT_ICU PROC

    ;ALL OF THE INTERNAL PERIPHERAL INTERRUPT REQUEST LATCHES SHOULD
    ;BE CLEARED FOR SAFE MEASURE

    MOV     DX, SCUIRL
    MOV     AX, 0F00H
    OUT     DX, AX
    MOV     DX, TIMIRL
    OUT     DX, AX
    MOV     DX, DMAIRL
    OUT     DX, AX

    ;INITIALIZE SLAVE 82C59 MODULE

    MOV DX, SPICP0           ;ICW1 ->SPICP0
    XOR AH, AH               ;CLEAR RESERVED BITS
    MOV AL, 11H              ;EDGE TRIG, CASCADE, IC4 REQD
    OUT DX, AL

    MOV DX, SPICP1           ;SET BASE INTERRUPT TYPE AT 104 FOR SLAVE
    MOV AL, SLAVE_BASE_TYPE ;ICW2 ->SPICP1
    OUT DX, AL               ;BASE ADDRESS AT 01A0H

    MOV DX, SPICP1           ;SLAVE ID
    MOV AL, 7                ;ICW3 ->SPICP1
    OUT DX, AL               ;ID=7 ALWAYS FOR INTERNAL SLAVE

    MOV DX, SPICP1           ;ICW4 ->SPICP1
    MOV AL, 1                ;NO SFNM, NO AEOI, FACTORY TEST CODES SET
    OUT DX, AL

    MOV DX, SPICP1           ;OCW1 ->SPICP1

```

Example A-1. Initialization Sequence and ISR Examples (Sheet 8 of 8)

```

MOV AL, 07FH          ;UNMASK INT7 (IR7 OF SLAVE)
OUT DX, AL

;INITIALIZE MASTER MODULE

MOV DX, MPICP0       ;ICW1 ->MPICP0
XOR AH, AH
MOV AL, 11H          ;EDGE TRIG, CASCADE, IC4 REQD
OUT DX, AL

MOV DX, MPICP1       ;ICW2 ->MPICP1
MOV AL, MASTER_BASE_TYPE ;BASE TYPE FOR MASTER
OUT DX, AL           ;BASE ADDRESS AT 0180H

;SET BASE INTERRUPT TYPE FOR THE MASTER AT TYPE 96
;WHICH IS EQUIVALENT TO A BASE ADDRESS OF 180H. BETWEEN
;THE BASE TYPES OF THE MASTER AND THE SLAVE, THERE IS A
;CONTIGUOUS BLOCK FROM 180H TO 1BCH FOR THE INTERRUPT VECTORS

```

ADDRESS	IR LINE	TYPE	FUNCTION	82C59
;-----				
;1BC	7	111	INT7	SLAVE
;1B8	6	110	TXI0	SLAVE
;1B4	5	109	RXI0	SLAVE
;1B0	4	108	TMI2	SLAVE
;1AC	3	107	DMAI3	SLAVE
;1A8	2	106	DMAI2	SLAVE
;1A4	1	105	TMI1	SLAVE
;1A0	0	104	TMI0	SLAVE
;19C	7	103	SLAVE	MASTER
;198	6	102	INT6	MASTER
;194	5	101	INT5	MASTER
;190	4	100	INT4	MASTER
;18C	3	99	INT3	MASTER
;188	2	98	INT2	MASTER
;184	1	97	INT1	MASTER
;180	0	96	INT0	MASTER

```

MOV DX, MPICP1       ;ICW3 ->MPICP1
MOV AL, 80H          ;SLAVE MODULE IS ALWAYS ON IR7
OUT DX, AL

MOV DX, MPICP1       ;ICW4 ->MPICP1
MOV AL, 1            ;NO SFNM, NO AEOI, FACTORY TEST CODES
OUT DX, AL

MOV DX, MPICP1       ;OCW1 ->MPICP1
MOV AL, 0H          ;UNMASK ALL MASTER IR LINES
OUT DX, AL

```

```

RET
INIT_ICU ENDP

```

```

EC_CODE ENDS
END MAIN

```

A.2 ISR for Unexpected or Uninitialized Interrupts

When programming the interrupt control unit, it is important to take unexpected events into consideration. It is possible for an interrupt to occur that was unintentional or unwanted and therefore software should exist to prevent system failure.

The following two subroutines can be used to direct unused interrupts to a common interrupt service routine where they can be handled appropriately to return control back to the main program. These subroutines were not added in Example #1 because the evaluation board firmware already compensates for unwanted interrupts.

Example A-2. ISR for Unexpected or Uninitialized Interrupts (Sheet 1 of 2)

```

;*****
;PROCEDURE: FILL_UNWANTED_INTS
;
;WHENEVER AN UNEXPECTED/UNINITIALIZED INTERRUPT OCCURS, THE PROCESSOR WILL
;VECTOR TO THE UNWANTED_INT INTERRUPT SERVICE ROUTINE TO PREVENT SYSTEM
;HANG-UPS
;*****
FILL_UNWANTED_INTS PROC

;FILL ENTIRE INTERRUPT VECTOR TABLE WITH UNWANTED_INT VECTORS

        XOR AX, AX            ;CLEAR ACCUMULATOR
        MOV DS, AX           ;CLEAR DATA SEGMENT
        MOV DI, 0            ;START AT 0
        MOV CX, 256          ;DO 256 TIMES

FILL_OFFSETS:
        MOV WORD PTR DS:[DI], OFFSET UNWANTED_ISR
        ADD DI, 4             ;FILL OFFSETS
        LOOP FILL_OFFSETS

        MOV DI, 2            ;START AT 2
        MOV CX, 256          ;DO 256 TIMES

FILL_SEGMENTS:
        MOV WORD PTR DS:[DI], SEG UNWANTED_ISR
        ADD DI, 4             ;FILL SEGMENTS
        LOOP FILL_SEGMENTS

FILL_UNWANTED_INTS ENDP

;*****
;INTERRUPT SERVICE ROUTINE: UNWANTED_ISR
;
;WHENEVER AN UNEXPECTED/UNINITIALIZED INTERRUPT OCCURS, THE PROCESSOR WILL
;VECTOR TO THIS INTERRUPT SERVICE ROUTINE AND DISPLAY PATTERN1 ON 7SEG1
;AND PATTERN2 ON 7SEG2 THEN RETURN TO NORMAL PROGRAM EXECUTION
;*****
UNWANTED_ISR PROC
        MOV DX, _7SEG1
        MOV AL, PATTERN1
        OUT DX, AL
    
```

Example A-2. ISR for Unexpected or Uninitialized Interrupts (Sheet 2 of 2)

```
MOV DX, _7SEG2
MOV AL, PATTERN2
OUT DX, AL

IRET                ;RETURN TO NORMAL PROGRAM EXECUTION
UNWANTED_ISR ENDP
```