



SCSI / Ethernet IQ Module Board Manual

November 1996

Order Number: 272924-002



Information in this document is provided in connection with Intel products. No license, express or implied, by estoppel or otherwise, to any intellectual property rights is granted by this document. Except as provided in Intel's Terms and Conditions of Sale for such products, Intel assumes no liability whatsoever, and Intel disclaims any express or implied warranty, relating to sale and/or use of Intel products including liability or warranties relating to fitness for a particular purpose, merchantability, or infringement of any patent, copyright or other intellectual property right. Intel products are not intended for use in medical, life saving, or life sustaining applications.

Intel retains the right to make changes to specifications and product descriptions at any time, without notice.

*Third-party brands and names are the property of their respective owners. Contact your local Intel sales office or your distributor to obtain the latest specifications and before placing your product order.

Copies of documents which have an ordering number and are referenced in this document, or other Intel literature, may be obtained from:

Intel Corporation
P.O. Box 7641
Mt. Prospect, IL 60056-7641
or call 1-800-879-4683



CONTENTS

CHAPTER 1

INTRODUCTION

1.1	OVERVIEW	1-1
1.2	FEATURES.....	1-1
1.3	SPECIFICATIONS.....	1-1
1.4	RELATED INFORMATION	1-2
1.4.1	Ordering Information	1-2
1.4.2	Third-Party Vendor Contact Information	1-2
1.4.3	Intel Documentation	1-2
1.4.4	"Electronic" Information	1-3
1.4.5	Intel Customer Support Contacts.....	1-3

CHAPTER 2

INSTALLATION

2.1	INSTALLATION ON A HOST.....	2-1
2.2	JUMPER CONFIGURATION.....	2-1

CHAPTER 3

HARDWARE DESCRIPTION

3.1	INTRODUCTION	3-1
3.2	SPECIFICATIONS.....	3-2
3.3	ETHERNET PORTS	3-2
3.4	82557 ETHERNET CONTROLLER.....	3-2
3.5	DP83840 AND DP83223 PHYSICAL LAYER DEVICES.....	3-3
3.6	ETHERNET PORT LEDS	3-3
3.7	ETHERNET PORT CONNECTORS.....	3-3
3.8	SCSI PORTS	3-4
3.9	53C875 SCSI CONTROLLER	3-4
3.10	SCSI PORT CONNECTORS.....	3-4
3.11	SCSI PORT TERMINATION.....	3-4

CHAPTER 4

PROGRAMMING INFORMATION

4.1	INTRODUCTION	4-1
4.2	ETHERNET PORTS	4-1
4.3	ETHERNET ADDRESS ASSIGNMENTS	4-2
4.4	SCSI PORTS	4-3

**CHAPTER 5
CONNECTORS**

5.1	SCSI/ETHERNET IQ MODULE CONNECTOR.....	5-1
5.2	ETHERNET PORT CONNECTORS.....	5-3
5.3	SCSI PORT CONNECTORS.....	5-3
5.4	ASSEMBLY DRAWING.....	5-4
5.5	SCSI / FAST ETHERNET IQ MODULE BOARD COMPONENTS.....	5-5
5.6	IQSCSIFENET MODULE BOARD BILL OF MATERIALS.....	5-6

FIGURES

Figure 2-1.	SCSI/Ethernet IQ Module Installation on Host.....	2-2
Figure 2-2.	Host (left) and SCSI/Ethernet IQ Module (right).....	2-3
Figure 3-1.	SCSI/Ethernet IQ Module Block Diagram.....	3-1
Figure 5-1.	SCSI/Ethernet IQ Module Assembly Drawing.....	5-4

TABLES

Table 1-1.	Related Third-Party Information.....	1-2
Table 1-2.	Related Intel Documentation.....	1-2
Table 1-3.	Related Electronic Information.....	1-3
Table 1-4.	Intel Customer Support Telephone Numbers.....	1-3
Table 3-1.	SCSI/Ethernet IQ Module Interface Signal Assignment.....	3-2
Table 3-2.	SCSI/Ethernet IQ Module Power Requirements.....	3-2
Table 4-1.	Device Number Assignment.....	4-1
Table 5-1.	SCSI/Ethernet IQ Module Connector Pinout.....	5-1
Table 5-2.	100BaseTx Connector.....	5-3
Table 5-3.	SCSI Port Connectors.....	5-3
Table 5-4.	SCSI / Fast Ethernet IQ Module, Component Description.....	5-5
Table 5-5.	SCSI/Ethernet IQ Module, Bill of Materials.....	5-6

CHAPTER 1 INTRODUCTION

1.1 OVERVIEW

The SCSI/Ethernet IQ Module extends the I/O capabilities of its host board by providing two Ethernet and two SCSI ports. The SCSI/Ethernet IQ Module connects to the IQ Module Interface on the host board. The module may be hosted on an Intel IQ80960RP PCI card.

The IQ Module Interface supports up to four PCI devices. The standard signals defined for 32-bit PCI edge connectors are used for IQ Modules, with some exceptions. See the *IQ80960RP Evaluation Platform User's Guide* for more information on the IQ Module Interface.

1.2 FEATURES

- Two 10/100BaseTx type Ethernet ports, based on Intel's 82557 Fast Ethernet PCI Bus Controller, National Semiconductor's DP83840 Ethernet Physical Layer Device and National Semiconductor's DP83228 High Speed Networking Transceiver.
- Two 16-bit Ultra SCSI (40 Mbps) SCSI ports based on the Symbios Logic* SYM53C875 PCI-SCSI I/O Processor with UltraSCSI.

1.3 SPECIFICATIONS

Host Clock Signal:

- 33 MHz Maximum

Physical Characteristics:

- Length x Width x Height: 7.00" x 4.25" x 0.625"
- Occupies only one IQ Module Location
- Occupies only one PCI slot when installed on a PCI host

1.4 RELATED INFORMATION

1.4.1 Ordering Information

When ordering the SCSI/Ethernet IQ Module, refer to the module's product code name "IQSCSIFENET".

1.4.2 Third-Party Vendor Contact Information

In addition to the printed technical documentation — the "traditional" collection of product information — Intel is providing technical (and other) information to you electronically via FaxBACK, Application Bulletin Board Service (BBS) and Worlwide Web (WWW). The following subsections identify related technical information, sources for electronic file download, and technical support.

Table 1-1. Related Third-Party Information

Company	Product	Contact
Symbios Logic	<i>SYM53C875 PCI-SCSI I/O Processor with UltraSCSI Data Manual</i>	(800) 334-5454
PCI Special Interest Group	<i>PCI Local Bus Specification Revision 2.1</i>	(800) 433-5177 (US) (503) 693-6232 (Int'l) (503) 693-8344 (FAX)
National Semiconductor	DP83840 Ethernet Physical Layer Device DP83223 High Speed Networking Transceiver	(800) 272-9959

1.4.3 Intel Documentation

Documentation is available from you local Intel Sales Representative or Intel Literature Sales.

Intel Corporation
Literature Sales
PO Box 7641
Mt Prospect, IL 60056-7641
(800) 879-4683

Table 1-2. Related Intel Documentation

Document Title	Order #
<i>IQ80960RP Evaluation Platform User's Guide</i>	272913-001

1.4.4 "Electronic" Information

Up-to-date product and technical information is available electronically from these sources.

Table 1-3. Related Electronic Information

Intel's World-Wide Web (WWW) Location:¹	http://www.intel.com/
FaxBACK Service:	
US and Canada	800-628-2283
Europe	+44(0)793-496646
World-Wide	916-356-3105
Application Bulletin Board Service:	
up to 14.4 Kbaud line, World-Wide	916-356-3600
dedicated 2400 baud line, World-Wide	916-356-7209
Europe	+44(0)793-496340

¹ Intel's presence on the WWW is evolving rapidly; file locations may have changed after this manual was printed. If you are not finding the desired information, contact Customer Support for assistance.

1.4.5 Intel Customer Support Contacts

Table 1-4. Intel Customer Support Telephone Numbers

Customer Support (US and Canada):		800-628-8686
Country		
Literature		
Technical Support		
Australia National Sydney	Contact Local Distributor	008-257-307 61-2-975-3300 61-3-810-2141
Belgium, Netherlands, Luxembourg	010-4071-111	010-4071-111
Canada	800-468-8118	Contact Local Distributor
Finland	358-0-544-644	358-0-544-644
France	33-1-30-57-70-00	33-1-30-57-72-22
Germany	49-89-90992-257	Hardware: 49-89-903-8529 Software: 49-89-903-2025
Israel	972-3-498080	972-3-548-3232
Italy	39-02-89200950	39-02-89200950
Japan	Contact Local Distributor	0120-1-80387
Sweden	46-8-7340100	46-8-7340100
United States	800-548-4725	800-628-6249

CHAPTER 2 INSTALLATION

2.1 INSTALLATION ON A HOST

WARNING

Static discharge can severely damage integrated circuits. The host board and SCSI/Ethernet IQ Module should only be handled with proper static protection. SCSI/Ethernet IQ Modules should always be installed with power to the host board OFF. Mounting or dismounting a module with the host power ON could permanently damage the circuitry on the module.

Refer to the SCSI/Ethernet IQ Module's host board user's manual for mounting locations.

To install the SCSI/Ethernet IQ Module (Figure 2-1) proceed with the following steps:

1. Remove the corresponding blank mounting bracket from the host board.
 - a. For PCI hosts, a PCI bracket for the SCSI/Ethernet IQ Module is supplied with the module. The PCI bracket is mounted to the host board using two small slotted screws, also supplied.
2. SCSI/Ethernet IQ Modules mount "face down", that is, with the component side of the module facing the component side of the host.
 - a. Hold the module upside down over the host board.
 - b. Carefully tip the 10/100BaseTx connector of the module through the opening in the host mounting bracket.
 - c. Rotate the opposite (120-pin connector) edge of the module downward.
 - d. Align the module and host connectors.
 - e. With the module and host aligned, press the two assemblies together, fully mating the connectors.
3. Secure the mounting hardware, four nylon screws hold the module to spacers on the host.

2.2 JUMPER CONFIGURATION

There are two jumpers on the SCSI/Ethernet IQ Module, located near the SCSI port connectors. Each jumper controls active termination for its SCSI port. The default position is ON, where termination is connected. See CHAPTER 3 for more information about SCSI port termination. See CHAPTER 5 for the location of the termination jumpers.

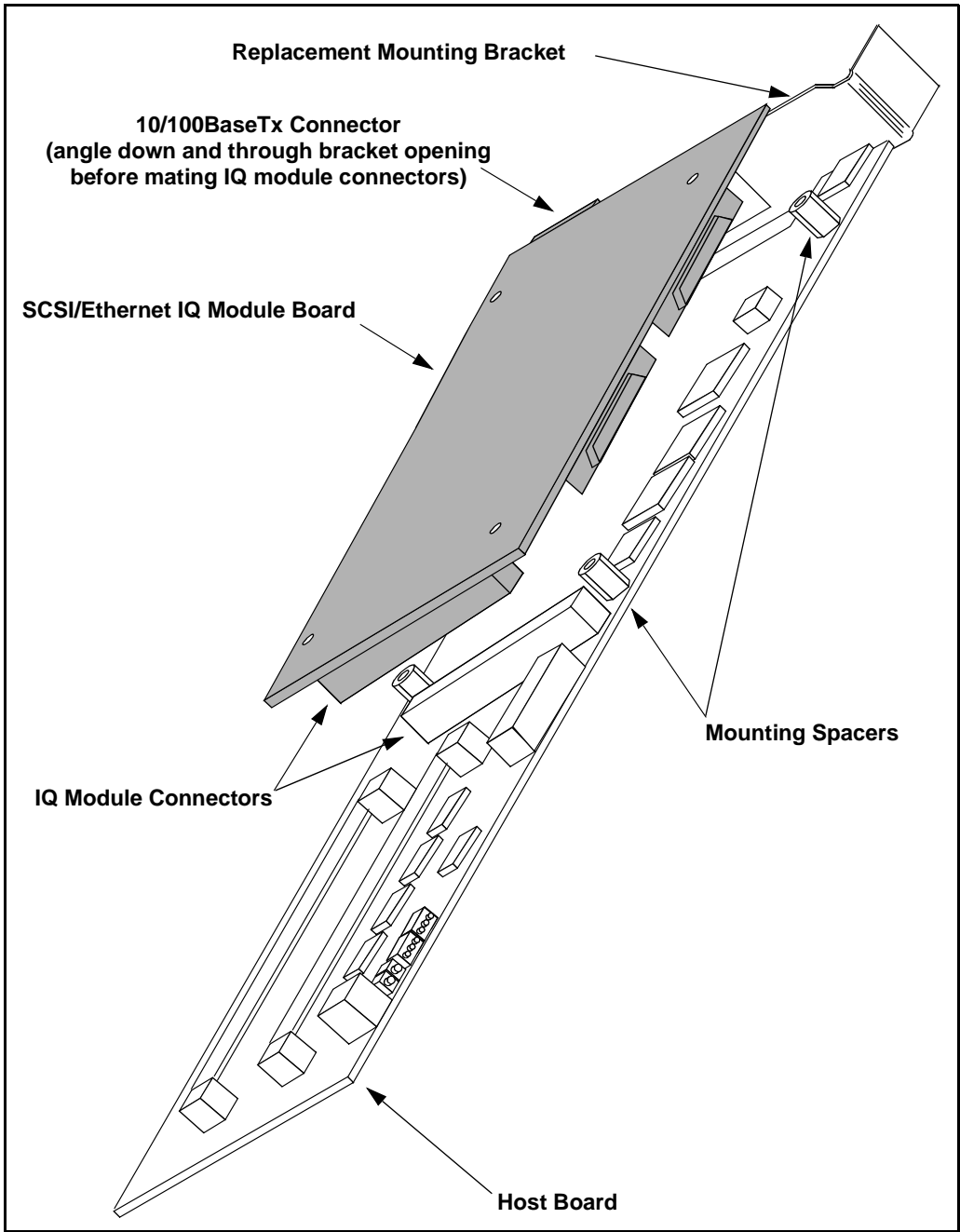

Figure 2-1. SCSI/Ethernet IQ Module Installation on Host

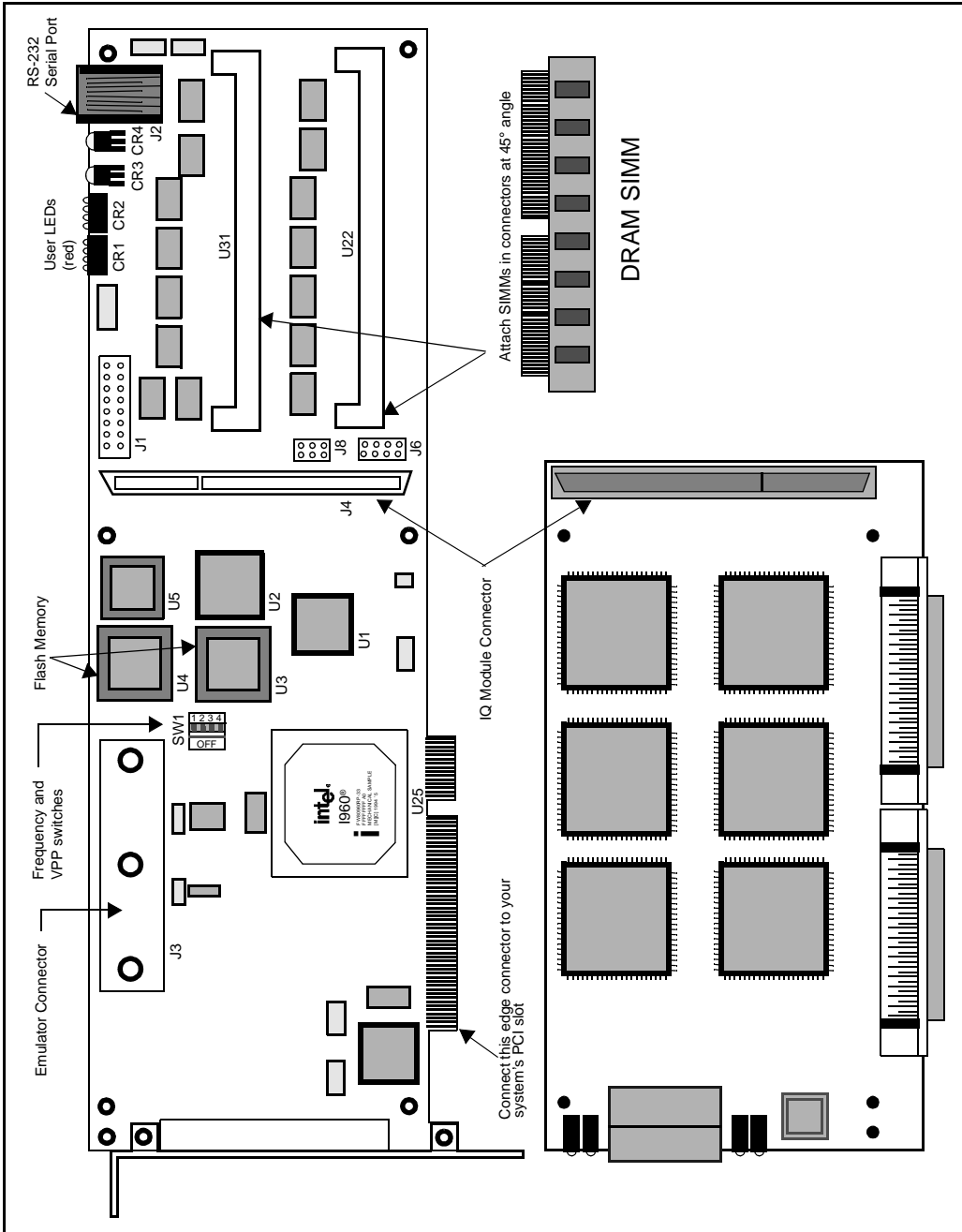

Figure 2-2. Host (left) and SCSI/Ethernet IQ Module (right)

CHAPTER 3 HARDWARE DESCRIPTION

3.1 INTRODUCTION

This chapter describes the hardware and general operation of the SCSI/Ethernet IQ Module. The VLSI circuits are not described in detail. The user should consult the manuals and data sheets listed in Section 1.4, RELATED INFORMATION (pg. 2), for a detailed description of these devices. Connectors are not covered in detail in this chapter, see CHAPTER 5, CONNECTORS, for more information. Consult CHAPTER 4 for software and programming information. The SCSI/Ethernet IQ Module has four PCI devices, two PCI-Ethernet controllers and two PCI-SCSI controllers. The Ethernet controllers are Intel's 82557 Fast Ethernet PCI Bus Controller. The SCSI controllers are Symbios Logic's SYM53C875 PCI-SCSI I/O Processor with UltraSCSI.

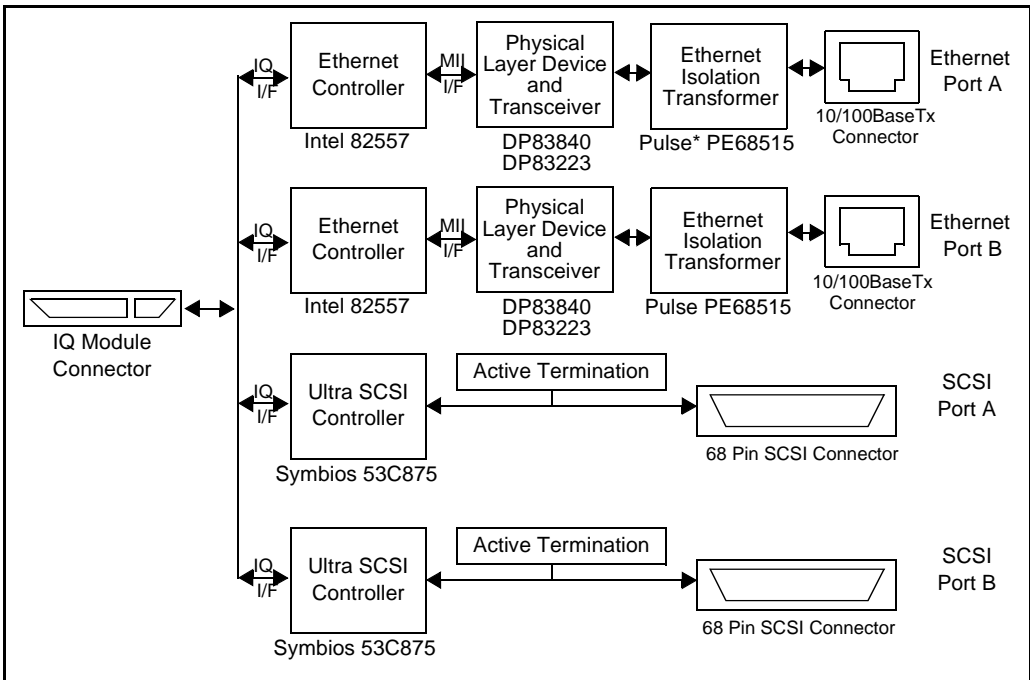

Figure 3-1. SCSI/Ethernet IQ Module Block Diagram

A block diagram of the SCSI/Ethernet IQ Module is shown in Figure 3-1. As the block diagram shows, all four ports are independent.

To support up to four devices on the SCSI/Ethernet IQ Module interface, the host board supplies four clock, arbitration and interrupt signals to the IQ connector. Additionally, the host board does not provide IDSEL signals to the SCSI/Ethernet IQ Module interface for PCI configuration cycles. As shown in Table 3-1, the SCSI/Ethernet IQ Module connects AD16 through AD19 to IDSEL. The clock, arbitration, and interrupt resources are assigned as shown in Table 3-1.

Table 3-1. SCSI/Ethernet IQ Module Interface Signal Assignment

SCSI/Ethernet IQ Module Port	Clocking	Arbitration	IDSEL	Interrupt
E-Net port A	CLK-A	REQ0/GNT0	AD16	IRQ-A
E-Net port B	CLK-B	REQ1/GNT1	AD17	IRQ-B
SCSI port A	CLK-C	REQ2/GNT2	AD18	IRQ-C
SCSI port B	CLK-D	REQ3/GNT3	AD19	IRQ-D

3.2 SPECIFICATIONS

Table 3-2. SCSI/Ethernet IQ Module Power Requirements

Voltage	Current Typical	Current Maximum
+3.3 V	0 A	0 A
+5 V	4.05 A	5.11 A
+12 V	0 A	0 A
-12 V	0 A	0 A

3.3 ETHERNET PORTS

Both Ethernet ports are 10/100BaseTx type based on Intel's 82557 Fast Ethernet PCI Bus Controller, National Semiconductor's DP83840 Physical Layer Device and National Semiconductor's DP83223 High Speed Networking Transceiver.

The 82557 is the core component of the Ethernet interface. It uses a PCI bus interface to communicate with the host, and a MII (Media Independent Interface) to communicate with a physical layer device.

3.4 82557 ETHERNET CONTROLLER

The 82557 contains a 32-bit PCI bus master interface that interacts with the host memory to access data for transmission or deposit received data.

The 82557 has large transmit and receive FIFOs that are unidirectional and independent of each other. The FIFOs provide temporary storage area for frames as they are received or transmitted. The FIFOs allow the 82557 to withstand long PCI latencies without losing incoming data or corrupting outgoing data.

The interface on the 82557 for FLASH support is not used on the SCSI/Ethernet IQ Module. The EEPROM interface has a serial EEPROM attached and is used to store the port's Ethernet address.

3.5 DP83840 AND DP83223 PHYSICAL LAYER DEVICES

The National Semiconductor DP83840 and DP83223 provide the physical layer interface function for a 100BaseTx or 10BaseT Ethernet network.

The host side of the DP83840 connects to the Ethernet controller using the IEEE MII (Media Independent Interface). The DP83840 does not have a separate host interface; internal registers are accessed using the MII. The 100Mbps line side of the DP83840 connects to the DP83223 which in turn connects to the Ethernet isolation transformer. The 10Mbps line side of the DP83840 connects directly to the Ethernet isolation transformer.

When receiving, the DP83840 and DP83223 physical layer pair recover data and clock from the incoming signals. The recovered data stream is then decoded and output to the Ethernet controller through the MII. When transmitting, the physical layer pair receive binary data from the MII, then encode and transmit that data to the network.

The SCSI/Ethernet IQ Module configures the DP83840 to perform auto-negotiation per IEEE 802.3u. Auto-negotiation ensures that the highest performance protocol will be selected based on the ability of the SCSI/Ethernet IQ Module link partner.

3.6 ETHERNET PORT LEDs

Each Ethernet port on the SCSI/Ethernet IQ Module has four LEDs driven by the DP83840 that provide a visual indication of network status:

- The LED labeled "LNK" indicates link status.
- The LED labeled "ACT" indicates network activity. The "ACT" LED blinks when there is transmit or receive activity.
- The LED labeled "100" is on continuously when the port is connected to a 100 Mbps network.
- The LED labeled "FDX" indicates full duplex mode status. The LED is on continuously when in full duplex mode.

3.7 ETHERNET PORT CONNECTORS

The Ethernet ports on the SCSI/Ethernet IQ Module connect to a dual, shielded RJ45 (modular phone type) connector that conforms to the 10/100BaseTx specification. The connector pin-out can be found in CHAPTER 5. The Ethernet ports are indicated on the SCSI/Ethernet IQ Modules front panel and on the assembly drawing in CHAPTER 5.

3.8 SCSI PORTS

Both SCSI ports are single-ended 16-bit UltraSCSI (40 Mbps) SCSI ports based on the Symbios Logic SYM53C875 PCI-SCSI I/O Processor with UltraSCSI. The 53C875 is the core component of the SCSI interface. It uses a PCI interface to communicate with the host and connects directly to the SCSI bus.

3.9 53C875 SCSI CONTROLLER

The 53C875 is an intelligent SCSI host adapter which includes a high performance SCSI core, a 32-bit PCI bus master DMA core and an integrated SCSI SCRIPTS processor.

The SCSI core supports the 8- or 16-bit data bus. It supports UltraSCSI synchronous transfer rates up to 40 Mbps, SCSI-2 synchronous transfer rates up to 20 Mbps and asynchronous transfer rates up to 10 Mbps on a 16-bit SCSI bus.

The 32-bit PCI bus master DMA core is tightly coupled to the SCSI core through the SCRIPTS processor, which supports uninterrupted scatter/gather memory operations. A 536 byte FIFO allows the 53C875 to support up to 128 longword bursts across the PCI interface.

The SCRIPTS processor executes complex SCSI bus sequences independently of the host CPU. Algorithms written in SCSI SCRIPTS control the actions of the SCSI and DMA cores and are executed from the host boards RAM.

3.10 SCSI PORT CONNECTORS

Each SCSI port connects to a 68-pin high density D-type connector on the top edge of the SCSI/Ethernet IQ Module PCB. These connectors conform to the "non-shielded connector" of the SCSI-2 and UltraSCSI extension of the SCSI-3 specification. The pin-out of these connectors conforms to the "connector contact assignments for the single ended primary bus" of the SCSI-2 and UltraSCSI extension of the SCSI-3 specification. The SCSI port connector pin-outs can be found in CHAPTER 5.

3.11 SCSI PORT TERMINATION

The SCSI specification calls for all signals not defined as RESERVED, GROUND or TERMPWR to be terminated at each end of the cable. Additionally, the UltraSCSI extension of the SCSI-3 specification requires active termination in single ended UltraSCSI systems. The SCSI/Ethernet IQ Module uses an integrated active terminator device that has reduced line capacitance for operation at UltraSCSI transfer rates.

If the SCSI/Ethernet IQ Module SCSI port is not at either end of the SCSI cable, then the termination must be disconnected. A two position jumper near each SCSI port connector is used to disconnect or turn off the active termination. The jumper shunt in the ON position connects the termination and the jumper shunt in the OFF position disconnects the termination.

CHAPTER 4

PROGRAMMING INFORMATION

4.1 INTRODUCTION

This chapter provides software and programming information for the SCSI/Ethernet IQ Module. This chapter does not contain a complete list of all registers in all devices. The user should consult the manuals and data sheets listed in Section 1.4, RELATED INFORMATION (pg. 2), for a detailed description of registers and configuration information. See CHAPTER 3 for hardware and general operation of the SCSI/Ethernet IQ Module.

The SCSI/Ethernet IQ Module connects to the IQ Module Interface of its host board. The IQ Module Interface is a 32-bit PCI bus conforming to the *PCI Local Bus Specification* Revision 2.1, with exceptions noted in the host board users manual and CHAPTER 3.

For PCI Type 0 configuration cycles, the device number assignment is as shown in Table 4-1.

Table 4-1. Device Number Assignment

SCSI/Ethernet IQ Module Port	IDSEL	Device
E-NET port A	AD16	Number 5
E-NET port B	AD17	Number 6
SCSI port A	AD18	Number 7
SCSI port B	AD19	Number 8

4.2 ETHERNET PORTS

The 82557 establishes a shared memory communication system with the host CPU. This shared memory is divided into three parts: the Control/Status Registers (CSR), the Command Block List (CBL) and the Receive Frame Area (RFA). The CSR resides on-chip and can be accessed by either I/O or memory cycles, while the rest of the 82557 memory structures reside in system (host) memory. The first 8 bytes of the CSR is called the System Control Block (SCB). The SCB serves as a central communication point for exchanging control and status information between the host CPU and the 82557.

The host software controls the state of the 82557 Command Unit (CU) and Receive Unit (RU) (for example Active, Suspended, Idle) by writing commands to the SCB. The 82557 posts the status of the CU and RU in the SCB Status word and indicates status changes with an interrupt. The SCB also holds pointers to a linked list of action commands called the CBL and a linked list of received resources called the RFA.

Parameters which must be established prior to making the 82557 operational included internal configuration values (established using the Configure Command) and assigning an individual Ethernet address (using the Individual Address Setup Command). Note that the aforementioned shared memory communication architecture must be established prior to the execution of 82557 action commands. Refer to the 82557 manual for further information regarding device configuration.

4.3 ETHERNET ADDRESS ASSIGNMENTS

The ethernet address is pre-programmed at the factory and is stored in the on-board serial EEPROM. The following describes the ethernet address assignment.

To provide a unique ethernet address for all IQ modules with Ethernet ports, an algorithm has been established that combines the IQ module number, the port number and the board's serial number.

The Ethernet address is a six byte number. The first three bytes are assigned to Cyclone Microsystems and are fixed at:

\$ 00 80 4D

The last three bytes are broken into three binary fields:

b XXXX XXXX YYZZ ZZZZ ZZZZ ZZZZ

The first binary field, XXXX XXXX is the Module ID, in Hex. The SCSI/Ethernet IQ Module ID is 73 converted (\$49).

The second binary field, YY is the port number. For the SCSI/Ethernet IQ Module there are two ethernet ports:

E-Net Port A, YY = 00

E-Net Port B, YY = 01

The third binary field, ZZ ZZZZ ZZZZ ZZZZ is the modules serial number converted to hex. For example, if the module serial number is 1234 then:

1234d = \$4D2

ZZ ZZZZ ZZZZ ZZZZ = 00 0100 1101 0010

The complete ethernet address for an SCSI/Ethernet IQ Module with serial number 1234 would be:

E-Net Port A = \$ 00 80 4D 44 04 D2

E-Net Port B = \$ 00 80 4D 49 44 D2

4.4 SCSI PORTS

This section defines specific setup requirements for the SYM53C875 processors to ensure proper operation of the SCSI/Ethernet IQ Module. To use Ultra SCSI capabilities of the SYM53C875, it is necessary to enable the clock doubler. This involves properly configuring registers STEST1 (register 4DH), STEST3 (register 4FH), and SCNTL1 (register 01H) of the SYM53C875. See the *SYM53C875 PCI-SCSI I/O Processor with UltraSCSI Data Manual* for further information.

The default operating mode for the SCSI ports is 8-bit, 10 Mbps transfer rate. The SYM53C875 supports both wide-SCSI (16-bit) and Ultra SCSI, resulting in a maximum potential transfer rate of 40 Mbps (16-bit). Operation in wide and/or Ultra SCSI modes requires negotiation with the initiator or target. See the SCSI specification for the SCSI message system definition.

The Synchronous Clock Conversion Factor bits SCF2, SCF1, and SCF0 (bits[6:4]) of SCSI Control Three Register (SCNTL3, register 03H) should be set to match the data transfer period negotiated with the target. For transfer periods of 100 ns or greater, set to 0,1,1 to divide the SCLK frequency of 80 MHz by 2 (for a 40 MHz clock input internally to the SYM53875). For transfer periods of less than 100 ns, set these bits to 0,0,1 to divide SCLK by 1. Set the Clock Conversion Factor bits CCF2, CCF1, and CCF0 (bits[2:0]) to 1,0,1.

NOTE:

The SCSI/Ethernet IQ Module uses a 40 MHz external SCLK which is doubled by the SYM53C875 to support UltraSCSI functions.

Host bus parity checking should not be used. The MPEE bit (bit 3) of the Chip Test Four (CTEST4, register 21H) should be left at its default value of 0.

The SCSI Differential Mode bit DIF (bit 5) of the SCSI Test Register 2 (STEST2, register 4EH) should be left at its default value of zero. The SCSI/Ethernet IQ Module uses the single-ended transceiver pins of the SYM53C875.

CHAPTER 5 CONNECTORS

5.1 SCSI/ETHERNET IQ MODULE CONNECTOR

IQ Modules use an AMP Champ 0.050" FH board-to-board connector with 120 pins. AMP plug P/N 176380-4 is located on the host platform and attaches to receptacle AMP P/N 176372-5. This connector combination allows for a 12 mm (0.472") board-to-board spacing.

Table 5-1. SCSI/Ethernet IQ Module Connector Pinout

Pin	Signal	Pin	Signal
1	S_TRST	61	-12 V
2	+12 V	62	S_TCK
3	S_TMS	63	GND
4	S_TDI	64	N/C
5	+5 V	65	+5 V
6	S_INTA	66	+5 V
7	S_INTC	67	S_INTB
8	+5 V	68	S_INTD
9	CLK_C	69	S-REQ3
10	+5 V	70	S_REQ1
11	CLK_D	71	S_GNT3
12	GND	72	GND
13	GND	73	GND
14	S_GNT1	74	CLKA
15	S_RST	75	GND
16	+5 V	76	CLKB
17	S_GNT0	77	GND
18	GND	78	S_REQ0
19	S_REQ2	79	+5 V
20	S_AD30	80	S_AD31
21	3.3 V (Note 1)	81	S_AD29
22	S_AD28	82	GND
23	S_AD26	83	S_AD27
24	GND	84	S_AD25
25	S_AD24	85	3.3 V (Note 1)
26	S_GNT2	86	S_C/BE3
27	3.3 V (Note 1)	87	S_AD23
28	S_AD22	88	GND

Table 5-1. SCSI/Ethernet IQ Module Connector Pinout (Continued)

Pin	Signal	Pin	Signal
29	S_AD20	89	S_AD21
30	GND	90	S_AD19
31	S_AD18	91	3.3 V (Note 1)
32	S_AD16	92	S_AD17
33	3.3 V (Note 1)	93	$\overline{S_C/BE2}$
34	$\overline{S_FRAME}$	94	GND
35	GND	95	$\overline{S_IRDY}$
36	$\overline{S_TRDY}$	96	3.3 V (Note 1)
37	GND	97	$\overline{S_DEVSEL}$
38	$\overline{S_STOP}$	98	GND
39	3.3 V (Note 1)	99	$\overline{S_LOCK}$
40	N/C	100	$\overline{S_PERR}$
41	N/C	101	3.3 V (Note 1)
42	GND	102	$\overline{S_SERR}$
43	S_PAR	103	3.3 V (Note 1)
44	S_AD15	104	$\overline{S_C/BE1}$
45	3.3 V (Note 1)	105	S_AD14
46	S_AD13	106	GND
47	S_AD11	107	S_AD12
48	GND	108	S_AD10
49	S_AD9	109	\overline{GND}
50	$\overline{S_C/BE0}$	110	S_AD8
51	3.3 V (Note 1)	111	S_AD7
52	S_AD6	112	3.3 V (Note 1)
53	S_AD4	113	S_AD5
54	GND	114	S_AD3
55	S_AD2	115	GND
56	S_AD0	116	S_AD1
57	+5 V	117	$\overline{+5 V}$
58	N/C	118	N/C
59	+5 V	119	+5 V
60	+5 V	120	+5 V

Note 1: 3.3 V pins are decoupled to ground with 0.01 μ F capacitors to provide AC return paths.

5.2 ETHERNET PORT CONNECTORS

The Ethernet ports on the SCSI/Ethernet IQ Module connect to a dual, shielded RJ45 (modular phone type) connector that conforms to the 10/100BaseTx specification. The pinout for each Ethernet port is shown in Table 5-2.

Table 5-2. 100BaseTx Connector

Pin	Signal	Description
1	TX+	Output
2	TX-	Output
3	RX+	Input
4		Not Used
5		Not Used
6	RX-	Input
7		Not Used
8		Not Used

5.3 SCSI PORT CONNECTORS

Each SCSI port connects to a 68-pin high-density D-type connector on the top edge of the SCSI/Ethernet IQ Module. These connectors conform to the "non-shielded connector" of the SCSI-2 and UltraSCSI extension of the SCSI-3 specification. These connectors pinouts conform to the "connector contact assignments for the single ended primary bus" of the SCSI-2 and UltraSCSI extension of the SCSI-3 specification. The SCSI port connector pinout is shown in Table 5-3.

Table 5-3. SCSI Port Connectors

Pin	Signal	Pin	Signal	Pin	Signal	Pin	Signal
1	Ground	35	-DB12	18	TERMPWR	52	TERMPWR
2	Ground	36	-DB13	19	N/C	53	N/C
3	Ground	37	-DB14	20	Ground	54	Ground
4	Ground	38	-DB15	21	Ground	55	-ATN
5	Ground	39	-DBP1	22	Ground	56	Ground
6	Ground	40	-DB0	23	Ground	57	-BSY
7	Ground	41	-DB1	24	Ground	58	-ACK
8	Ground	42	-DB2	25	Ground	59	-RST
9	Ground	43	-DB3	26	Ground	60	-MSG
10	Ground	44	-DB4	27	Ground	61	-SEL
11	Ground	45	-DB5	28	Ground	62	-C/D
12	Ground	46	-DB6	29	Ground	63	-REQ
13	Ground	47	-DB7	30	Ground	64	-I/O
14	Ground	48	-DBP0	31	Ground	65	-DB8
15	Ground	49	Ground	32	Ground	66	-DB9
16	Ground	50	Ground	33	Ground	67	-DB10
17	TERMPWR	51	TERMPWR	34	Ground	68	-DB11

5.4 ASSEMBLY DRAWING

The layout or assembly drawing is shown in Figure 5-1. This figure can be used to identify Ethernet Ports A & B and SCSI Ports A & B. This figure also shows the location of the SCSI terminator jumpers.

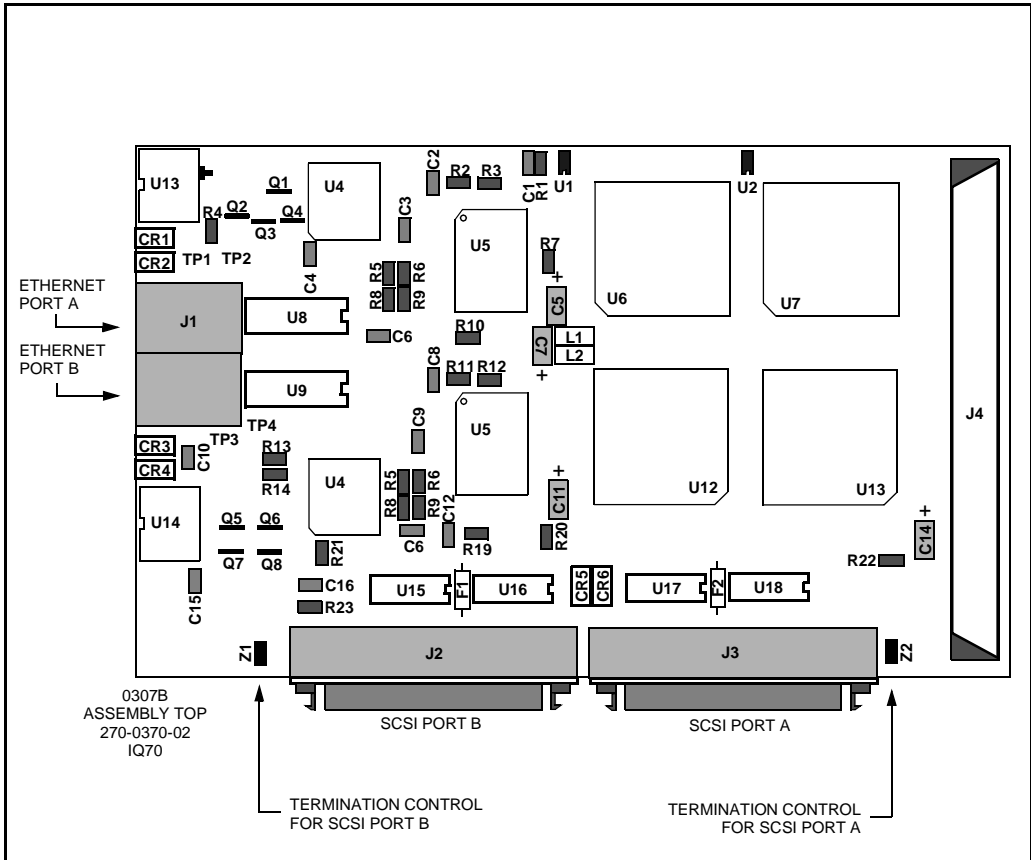

Figure 5-1. SCSI/Ethernet IQ Module Assembly Drawing

5.5 SCSI / FAST ETHERNET IQ MODULE BOARD COMPONENTS

Table 5-4. SCSI / Fast Ethernet IQ Module, Component Description

Component	Function
J1	10/100BaseTx, Dual-modular connector, Ethernet A & B
J2	68-pin Connector, SCSI Port B
J3	68-pin Connector, SCSI Port A
J4	120-pin Connector, IQ Module Interface
U1	Microchip* 93C46, Serial EEPROM
U2	Microchip 93C46, Serial EEPROM
U3	Kyocera* HC-1-TSE 50 MHz, TTL Oscillator
U4	National Semiconductor, DP83223, Transceiver
U5	National Semiconductor, DP83840, Physical Layer Device
U6	Intel 82557, Ethernet Controller
U7	Intel 82557, Ethernet Controller
U8	Pulse Engineering, PE-68515, Isolation Transformer
U9	Pulse Engineering, PE-68515, Isolation Transformer
U10	National Semiconductor, DP83223, Transceiver
U11	National Semiconductor, DP83840, Physical Layer Device
U12	Symbios Logic, 53C875, UltraSCSI Controller
U13	Symbios Logic, 53C875, UltraSCSI Controller
U14	Kyocera* HC-1-TSE 40 MHz, TTL Oscillator
U15	Unitrode, UCC5618, UltraSCSI Terminator
U16	Unitrode, UCC5618, UltraSCSI Terminator
U17	Unitrode, UCC5618, UltraSCSI Terminator
U18	Unitrode, UCC5618, UltraSCSI Terminator
Z1	Terminator Jumper, SCSI Port A
Z2	Terminator Jumper, SCSI Port B

5.6 IQSCSIFENET MODULE BOARD BILL OF MATERIALS

Table 5-5. SCSI/Ethernet IQ Module, Bill of Materials (Sheet 1 of 2)

Quantity	Part	Reference
2	93C46	U1, U2
1	OSC50 MHz	U3
2	DP83223A	U4, U10
2	DP83840	U5, U11
2	82557	U6, U7
2	PE-68515	U8, U9
2	53C875	U12, U13
1	OSC40 MHz	U14
4	UCC5618	U15, U16, U17, U18
2	SMT_BEAD, 2743019447	L1, L2
10	BEAD_1206, BLM31A02PT	L3, L4, L5, L6, L7, L8, L9, L10, L11, L12
2	1N4001	CR5, CR6
8	CMPT4401	Q1, Q2, Q3, Q4, Q5, Q6, Q7, Q8
1	CONN8TJ-SHL2	J1
2	CONN68	J2, J3
1	CONN_IQ_PCI	J4
2	FUSE2A	F1, F2
2	JUMP3X1	Z1, Z2
2	LED2HIGH	CR1, CR2, CR3, CR4
29	CAP, C, 1206, 0.1 μ F	C1, C8, C10, C15, C16, C17, C18, C19, C20, C21, C22, C28, C29, C30, C34, C35, C37, C38, C40, C42, C46, C47, C52, C53, C54, C55, C57, C58, C67
16	CAP, C, 1206, 0.01 μ F	C2, C3, C4, C6, C9, C13, C23, C26, C33, C36, C39, C41, C43, C45, C51, C56
4	CAP, C, 1206, 10 pF	C24, C25, C49, C50
4	CAP, C, 1206, 1000 pF	C12, C31, C32, C48
10	CAP, T, 3528, 6.8 μ F	C27, C44, C59, C60, C61, C62, C63, C64, C65, C66
2	CAP, T, 7343, 22 μ F	C5, C11
2	CAP, T, 7343, 33 μ F	C7 C14
2	R, 1/8W, 1206, 3.3 Kohm, 5%	R39, R40
4	R, 1/8W, 1206, 10 Kohm, 5%	R1, R22, R23, R24
16	R, 1/8W, 1206, 10 ohm, 5%	R14, R31, R34, R41, R48, R51, R52, R53, R54, R67, R68, R69, R78, R79, R80, R82
3	R, 1/8W, 1206, 22 ohm, 5%	R25, R26, R83
4	R, 1/8W, 1206, 39 ohm, 5%	R13, R32, R33, R81
6	R, 1/8W, 1206, 47 ohm, 5%	R35, R36, R37, R85, R86, R87

Table 5-5. SCSI/Ethernet IQ Module, Bill of Materials (Sheet 2 of 2)

Quantity	Part	Reference
8	R, 1/8W, 1206, 75 ohm, 5%	R55, R56, R57, R58, R63, R64, R65, R66
8	R, 1/8W, 1206, 000 ohm, 5%	R42, R43, R49, R50, R70, R71, R76, R77
12	R, 1/8W, 1206, 120 ohm, 5%	R5, R6, R15, R16, R44, R45, R46, R47, R59, R62, R73, R74
12	R, 1/8W, 1206, 200 ohm, 5%	R8, R9, R17, R18, R27, R28, R29, R30, R60, R61, R72, R75
2	R, 1/8W, 1206, 510 ohm, 5%	R38, R84
4	RNC4R8P, 4.7 Kohm, 5%	R2, R10, R11, R19
4	RNC4R8P, 10 Kohm, 5%	R3, R7, R12, R20
2	RNC4R8P, 470 ohm, 5%	R4, R21

