



AB-60

**APPLICATION
BRIEF**

**2/4/8-Mbit Smart Voltage
Boot Block Flash Memory
Family Overview**

December 1996

Order Number: 292154-004



Information in this document is provided in connection with Intel products. No license, express or implied, by estoppel or otherwise, to any intellectual property rights is granted by this document. Except as provided in Intel's Terms and Conditions of Sale for such products, Intel assumes no liability whatsoever, and Intel disclaims any express or implied warranty, relating to sale and/or use of Intel products including liability or warranties relating to fitness for a particular purpose, merchantability, or infringement of any patent, copyright, or other intellectual property right. Intel products are not intended for use in medical, life saving, or life sustaining applications.

Intel retains the right to make changes to specifications and product descriptions at any time, without notice.

Contact your local Intel sales office or your distributor to obtain the latest specifications and before placing your product order.

COPYRIGHT © INTEL CORPORATION 1996

Third-party brands and names are the property of their respective owners.

Copies of documents which have an ordering number and are referenced in this document, or other Intel literature, may be obtained from:

Intel Corporation
P.O. Box 7641
Mt. Prospect, IL 60056-7641

or call 1-800-879-4683

CG-041493

CONTENTS

	PAGE
1.0 INTRODUCTION	5
2.0 BOOT BLOCK ARCHITECTURE	5
3.0 PINOUT COMPATIBLE DENSITY UPGRADES	5
4.0 VOLTAGE OPTIONS	5
4.1 Smart 5 Flash	5
4.2 SmartVoltage (SVT) Flash	5
4.3 Standard Flash	5
5.0 UPGRADE NOTES	6
5.1 Transitioning SmartVoltage Designs to Smart 5 Flash	6
5.2 Upgrading from Standard Flash to SVT	6
5.3 WP# Pin on 8-Mbit 44-PSOP	6
6.0 PACKAGE PINOUTS	7
7.0 MEMORY MAPS	9
8.0 PRODUCT OFFERINGS	11
APPENDIX A: Ordering Information	13
APPENDIX B: Additional Information	14
FIGURES	
Figure 1. The SmartVoltage Technology Boot Block Line Features a Pinout-Compatible Upgrade Path	5
Figure 2. The 40-Lead TSOP Offers the Smallest Form Factor for Space-Constrained Applications	7
Figure 3. The 44-Lead PSOP Offers a Convenient Upgrade from JEDEC ROM Standards	7
Figure 4. The 48-Lead TSOP Offers the Smallest Form Factor for x16 Operation	8
Figure 5. The 56-Lead TSOP Offers Compatibility between 2 and 4 Mbits	8
Figure 6. Byte-Wide x8-Mode Memory Maps (Top Boot)	9
Figure 7. Byte-Wide x8-Mode Memory Maps (Bottom Boot)	9
Figure 8. Word-Wide x16-Mode Memory Maps (Top Boot)	10
Figure 9. Word-Wide x16-Mode Memory Maps (Bottom Boot)	10
Figure 10. Decoding the Product Names	13
TABLES	
Table 1. Write Protection Truth Table	6
Smart 5 Boot Block Products	11
SmartVoltage Boot Block Products	11
Standard Flash Boot Block Products	12

REVISION HISTORY

Number	Description
-001	Original Version
-002	Text updated. DU and WP# pin usage clarified. Note and "B" suffixes added to Figure 2. SmartVoltage Boot Block Products table: Speeds added to 28F800 and 28F008, 2.7V products added. Figure 10 updated.
-003	28F002BC, 28F200CE, 28F002BE, 28F400CE, 28F002BE line items added to products table.
-004	Smart 5 migration information added to text; products (28F200B5, 28F400B5, 28F800B5) added to product table. A ₁₇ on Pin 3 of 44-PSOP diagram changed to NC. (correction)



1.0 INTRODUCTION

This document includes a feature overview, pinouts, and memory maps for Intel's SmartVoltage boot block family, including 2/4/8-Mbit densities and Smart 5 flash option. These products offer Intel's boot block architecture with the SmartVoltage technology (SVT) outlined below. Follow the design steps in Section 5.0 to upgrade 12V V_{PP} designs to SVT.

2.0 BOOT BLOCK ARCHITECTURE

Intel's boot block architecture products offer the familiar features that optimize it for updateable firmware storage. These features include:

- Hardware-lockable boot block for secure kernel code storage
- Separate, switchable V_{PP} pin allowing absolute write protection
- Parameter blocks for parameter storage
- Main blocks for modular code updates, facilitating updateable firmware
- x8 or x16 configurable I/O operation
- RP# pin for reset and write protection
- PSOP and TSOP packages

3.0 PINOUT COMPATIBLE DENSITY UPGRADES

Intel provides pinout-compatible upgrades for the 2-Mbit, 4-Mbit, and 8-Mbit densities. The pinouts in Figures 2, 3, and 4 illustrate these compatible upgrade paths. Upgrade issues are discussed further in Section 5.

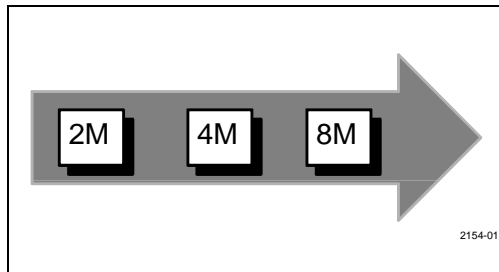

Figure 1. The SmartVoltage Technology Boot Block Line Features a Pinout-Compatible Upgrade Path

4.0 VOLTAGE OPTIONS

Intel offers flash memories in a number of different voltage options to provide the right features at the right price. The following sections discuss the various options.

4.1 Smart 5 Flash

Smart 5, designated by a B5 product name suffix, is a new voltage option for Intel SmartVoltage flash memories. Products supporting the Smart 5 option can read with V_{CC} at 5V and program/erase with V_{PP} at either 5V or 12V.

Smart 5 products allow:

1. Simple single-supply designs with both V_{CC} and V_{PP} at 5V
2. Fast factory programming with $V_{PP} = 12V$, which can save 20 cents/Mbit over single-supply flash

Smart 5 products save you money with simplified designs, lower manufacturing costs, and the lowest cost SmartVoltage flash components.

4.2 SmartVoltage (SVT) Flash

SmartVoltage technology, designated by a BV, CV, BE, or CE product name suffix, offers voltage flexibility:

- $V_{CC} = 2.7V-3.6V, 3.3V \pm 0.3V$ or $5V \pm 10\%$ with enhanced circuits to optimize low-voltage performance when low power consumption is critical.
- Program/erase operation with $V_{PP} = 5V$ for convenient in-system writes or $V_{PP} = 12V$ for fast production programming.

4.3 Standard Flash

Products that require $V_{PP} = 12V$ to program and erase are designated by BX, BL, or BC product name suffixes.

5.0 UPGRADE NOTES

This section discusses any issues that may be required when upgrading from one product line to another.

5.1 Migrating SmartVoltage Designs to Smart 5 Flash

If a design does not require low-voltage operation, consider migrating to Intel’s Smart 5 boot block flash. Smart 5 boot block products offer the same architecture as SmartVoltage boot block parts, but support only 5V V_{CC} . Designs requiring low-voltage operation should consider an SmartVoltage or Smart 3 product instead.

Other than the V_{CC} voltage support, some differences need to be accommodated. Full details on this topic can be found in the product datasheet and the application note, *AB-65 Migrating SmartVoltage Boot Block Designs to Smart 5*.

1. On-the-fly word-byte mode switching is no longer supported. Word-byte mode must be configured at power-up and remain stable during device operation.
2. Write operations are no longer specified as WE#- or CE#-controlled in favor of a simpler “unified” write method, which is compatible with either of the old methods.
3. Resets when a program or erase operation is in progress are handled differently. Smart 5 boot block products require a period of time, t_{PLRH} , to shut down the in-progress operation, and are unavailable for reads or writes during that time. An RC delay circuit between the system CPU and the system reset signal may be needed to allow the flash to reset properly before CPU initialization begins.

5.2 Upgrading from Standard Flash to SVT

If you have designs using standard 12V V_{PP} boot block products, you must adhere to the following design steps to ensure you can upgrade to SVT:

1. If 5V program/erase is desired, allow for connecting V_{PP} to 5V and disconnecting V_{PP} from 12V.
2. If switching V_{PP} on and off for write protection, switch to GND instead of V_{CC} .

3. Connect WP# (DU “Don’t Use” on BX/BL products) to V_{CC} , GND, or a control signal. This pin should not be left floating. The DU pin on BX/BL products can be driven to a logic-level in order to provide upgrade compatibility. The WP# pin replaces the DU pin and is used in conjunction with the V_{PP} and RP# pins to control write protection of the boot block.

Although most of the significant timing specifications are the same, some differences in power and timing specs must be accounted for. Full details on this topic can be found in the product datasheet and the application note, *AP-611 Boot Block Compatibility: 2/4-Mbit BX/BL with 2/4/8-Mbit BV*.

5.3 WP# Pin on 8-Mbit 44-PSOP

The 8-Mbit in the 44-PSOP package does not have a WP# pin because no other pins were available for the 8-Mbit upgrade address. Thus, in this density-package combination only, V_{HH} (12V) on RP# is required to unlock the boot block and unlocking with a logic-level signal is not possible. If this unlocking functionality is required, and 12V is not available in-system, please consider using the 48-TSOP package, which has a WP# pin and can be unlocked with a logic-level signal. All other density-package combinations have WP# pins.

Table 1 details the control of the locking functions using V_{PP} , RP#, and WP#. In the case of the 8-Mbit 44-PSOP, which does not have WP#, the last row of the truth table would not be available.

Table 1. Write Protection Truth Table

V_{PP}	RP#	WP#	Write Protection Provided
V_{IL}	X	X	All Blocks Locked
$\geq V_{PPLK}$	V_{IL}	X	All Blocks Locked (Reset)
$\geq V_{PPLK}$	V_{HH}	X	All Blocks Unlocked
$\geq V_{PPLK}$	V_{IH}	V_{IL}	Boot Block Locked
$\geq V_{PPLK}$	V_{IH}	V_{IH}	All Blocks Unlocked



6.0 PACKAGE PINOUTS

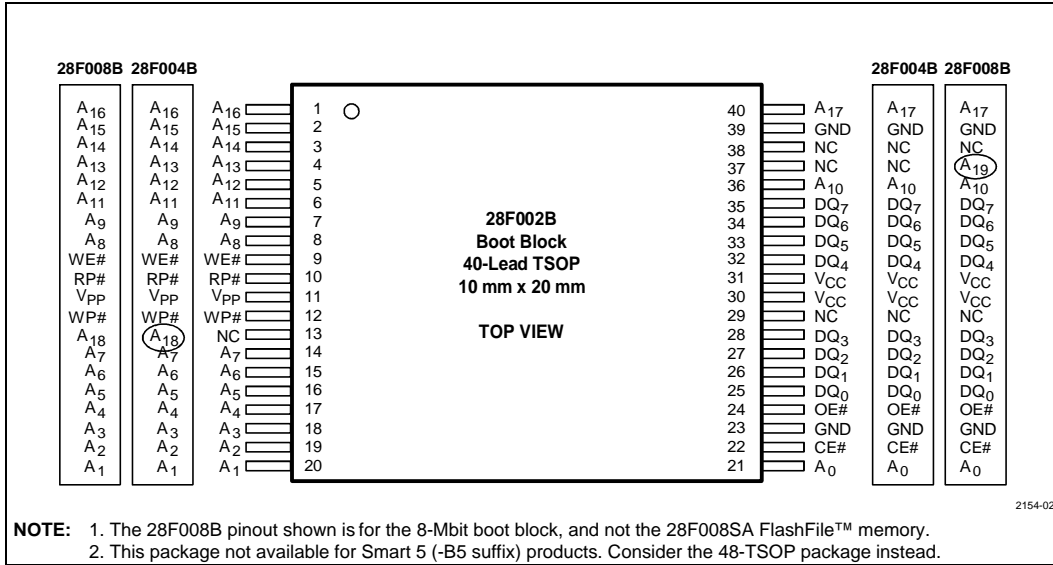

Figure 2. The 40-Lead TSOP Offers the Smallest Form Factor for Space-Constrained Applications

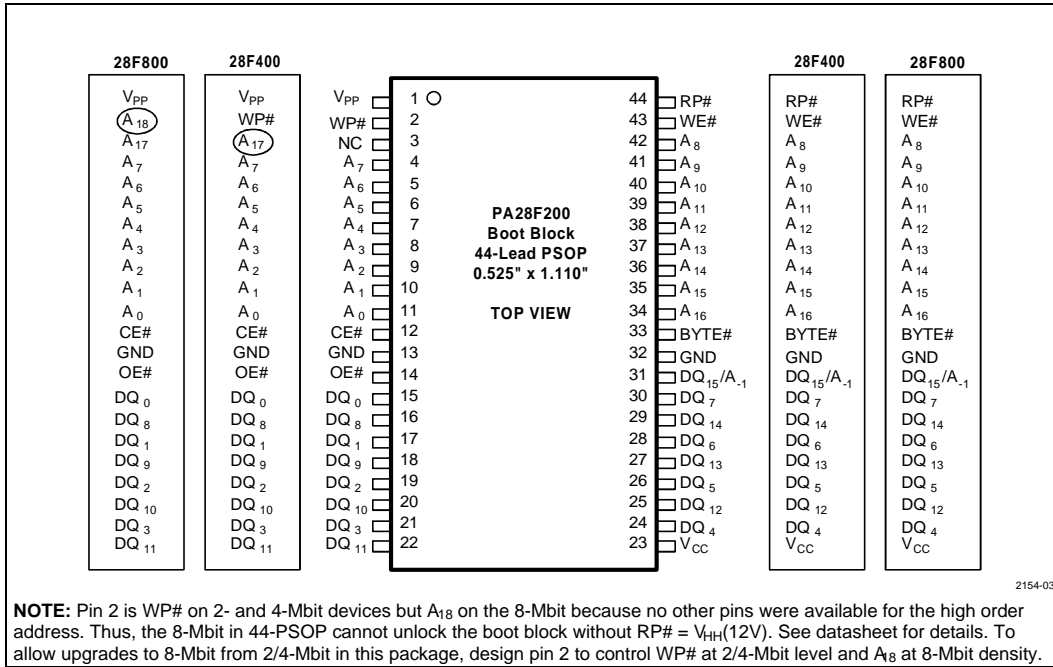

Figure 3. The 44-Lead PSOP Offers a Convenient Upgrade from JEDEC ROM Standards

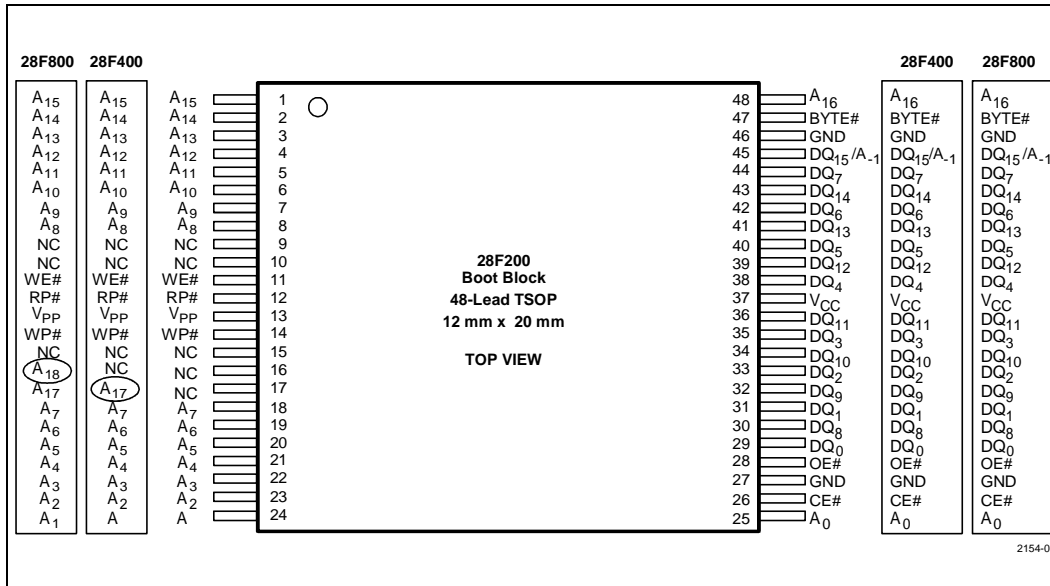
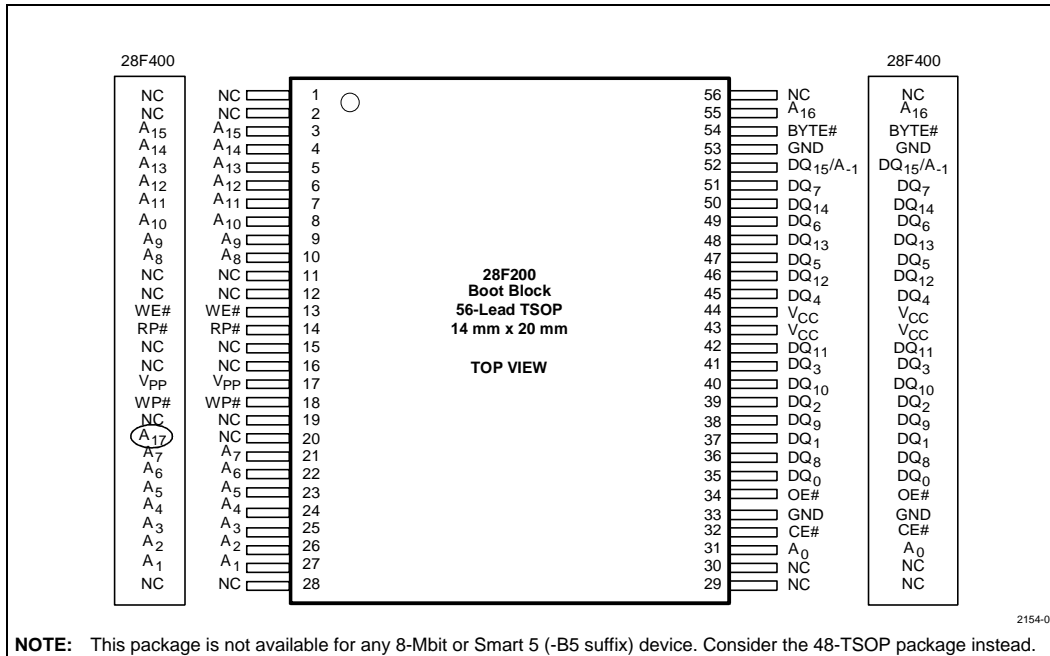

Figure 4. The 48-Lead TSOP Offers the Smallest Form Factor for x16 Operation



NOTE: This package is not available for any 8-Mbit or Smart 5 (-B5 suffix) device. Consider the 48-TSOP package instead.

Figure 5. The 56-Lead TSOP Offers Compatibility between 2 and 4 Mbits

7.0 MEMORY MAPS

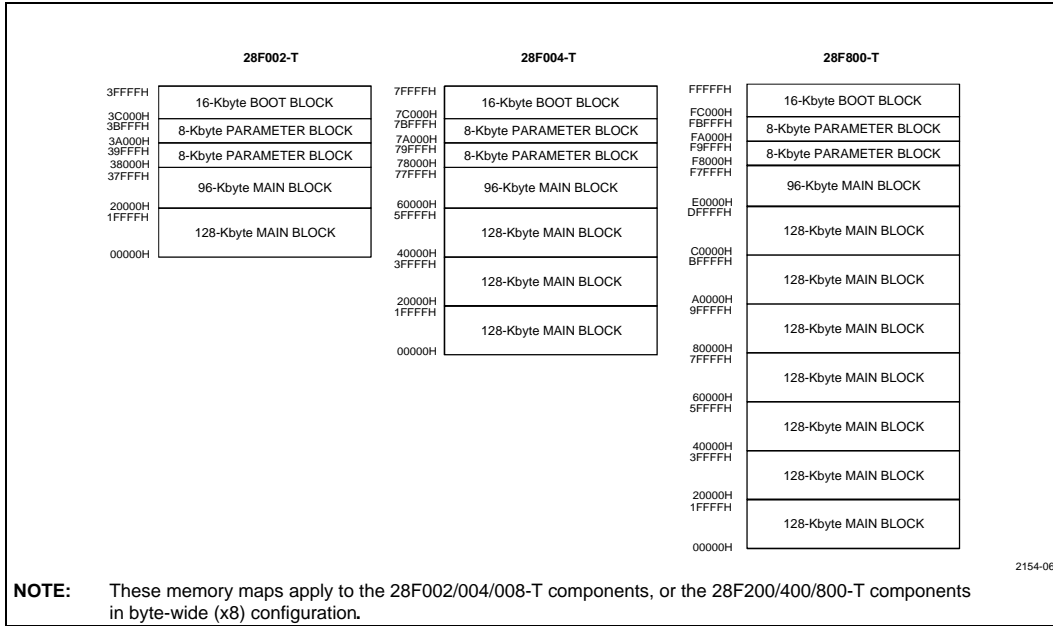

Figure 6. Byte-Wide x8-Mode Memory Maps (Top Boot)

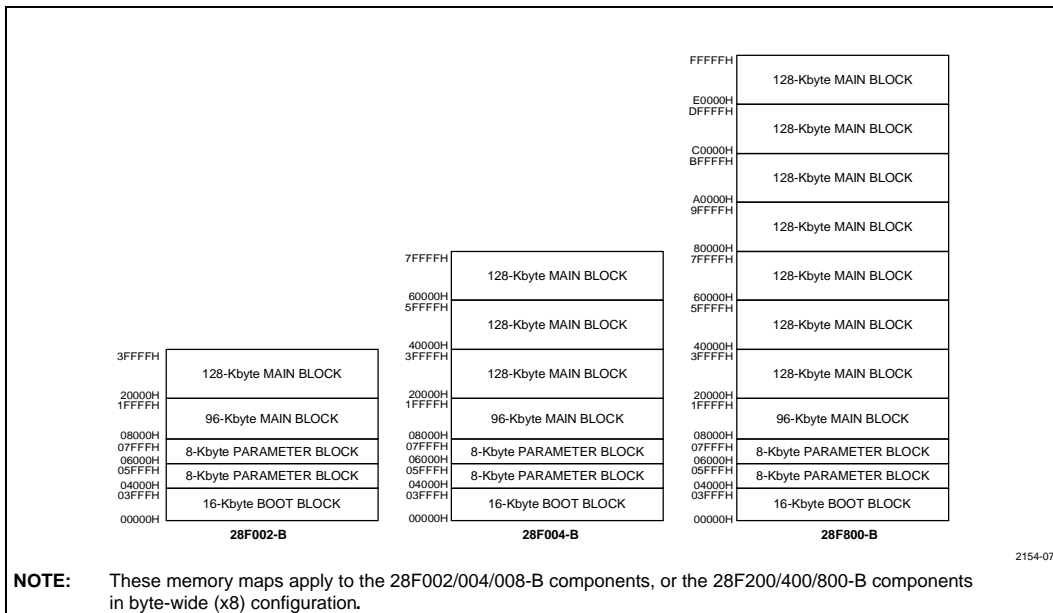

Figure 7. Byte-Wide x8-Mode Memory Maps (Bottom Boot)

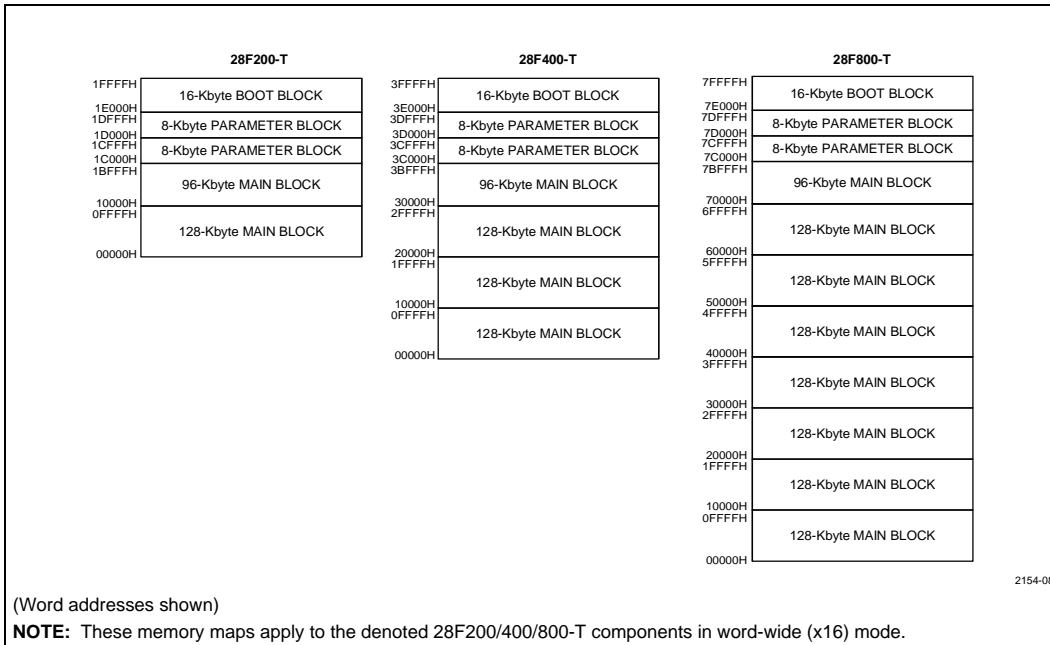

Figure 8. Word-Wide x16-Mode Memory Maps (Top Boot)

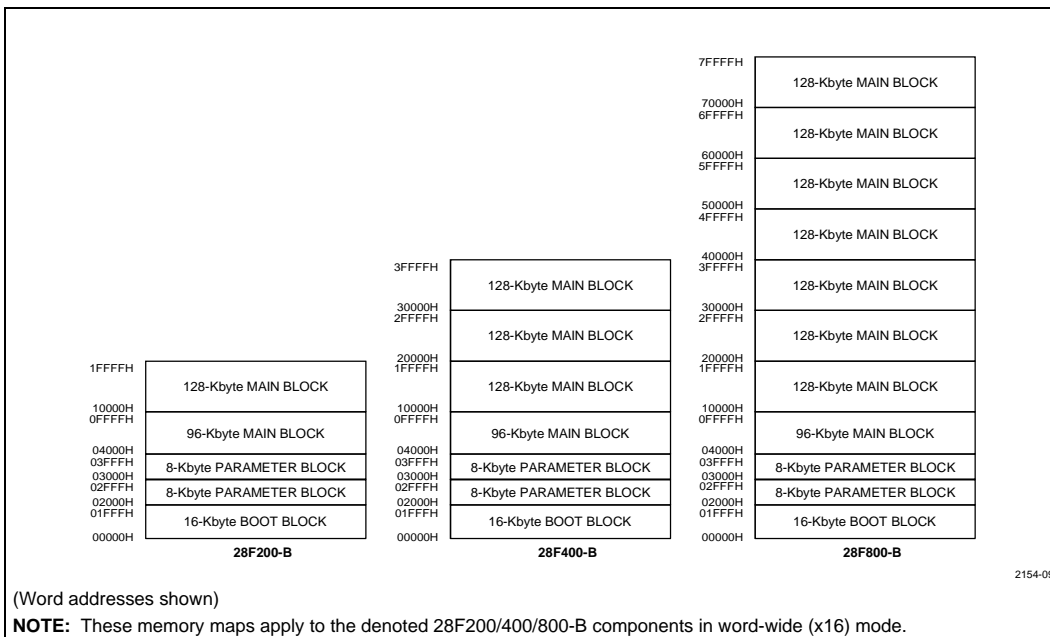

Figure 9. Word-Wide x16-Mode Memory Maps (Bottom Boot)

8.0 PRODUCT OFFERINGS

Smart 5 Boot Block Products

Product	Density x Org.	Pkg.	Speed (ns) (V _{CC} = 5V)	Extended Temp.
28F200B5	2 Mb, 256Kx8/128Kx16	44-PSOP, 48-TSOP	60, 80	√
28F400B5	4 Mb, 512Kx8/256Kx16	44-PSOP, 48-TSOP	60, 80	√
28F800B5	8 Mb, 1024Kx8/512Kx16	44-PSOP, 48-TSOP	70, 90	√

SmartVoltage Boot Block Products

Product	Density x Org.	Pkg	Speed (ns) (V _{CC} = 5V)	Speed (ns) (V _{CC} = 3.3V)	Speed (ns) (V _{CC} = 2.7V)	Extended Temp.
28F200BV	2 Mb, 256Kx8/128Kx16	44, 56	60, 80, 120	110, 150, 180		√
28F200CV	2 Mb, 256Kx8/128Kx16	48	60, 80, 120	110, 150, 180		√
28F002BV	2 Mb, 256Kx8	40	60, 80, 120	110, 150, 180		√
28F200CV	2 Mb, 256Kx8/128Kx16	48	60, 80, 120	110, 150, 180		√
28F200CE	2 Mb, 256Kx8/128Kx16	48	90		120	√
28F002BE	2 Mb, 256Kx8	40	90		120	√
28F400BV	4 Mb, 512Kx8/256Kx16	44, 56	60, 80, 120	110, 150, 180		√
28F400CV	4 Mb, 512Kx8/256Kx16	48	60, 80, 120	110, 150, 180		√
28F004BV	4 Mb, 512Kx8	40	60, 80, 120	110, 150, 180		√
28F400CE	4 Mb, 512Kx8/256Kx16	48	90		120	√
28F004BE	4 Mb, 512Kx8	40	90		120	√
28F800BV	8 Mb, 1024Kx8/512Kx16	44	70,120	120,150		√
28F800CV	8 Mb, 1024Kx8/512Kx16	48	70,120	120,150		√
28F008BV	8 Mb, 1024Kx8	40	70,120	120,150		√
28F800CE	8 Mb, 1024Kx8/512Kx16	48	90		120	√
28F008BE	8 Mb, 1024Kx8/512Kx16	40	90		120	√

NOTE:

BE/CE products operate over the V_{CC} ranges 2.7V–3.6V and 5V ±10%.

Standard Flash Boot Block Products

Product	Density x Org.	Pkg.	Speed (ns) (V _{CC} = 5V)	Speed (ns) (V _{CC} = 3.3V)	Extended Temperature
28F001BX	1 Mb, 128Kx8	P, N, E	70, 90, 120, 150		√
28F200BX	2 Mb, 256Kx8/128Kx16	PA, E	60, 80, 120		√
28F002BX	2 Mb, 256Kx8	E	60, 80, 120		√
28F200BL	2 Mb, 256Kx8/128Kx16	PA, E	(1)	150	√(2)
28F002BL	2 Mb, 256Kx8	E	(1)	150	√(2)
28F002BC	2 Mb, 256Kx8 ⁽³⁾	PA, E	80, 120		
28F400BX	4 Mb, 512Kx8/256Kx16	PA, E	60, 80, 120		√
28F004BX	4 Mb, 512Kx8	E	60, 80, 120		√
28F400BL	4 Mb, 512Kx8/256Kx16	PA, E	(1)	150	√(2)
28F004BL	4 Mb, 512Kx8	E	(1)	150	√(2)

NOTES:

1. The BL products also operate at 5V V_{CC} for programmer compatibility.
2. -20°C – +70°C operating range for Read; -0°C – +70°C for program and erase.
3. 28F002BC available in -T (top boot) version only.



APPENDIX A ORDERING INFORMATION

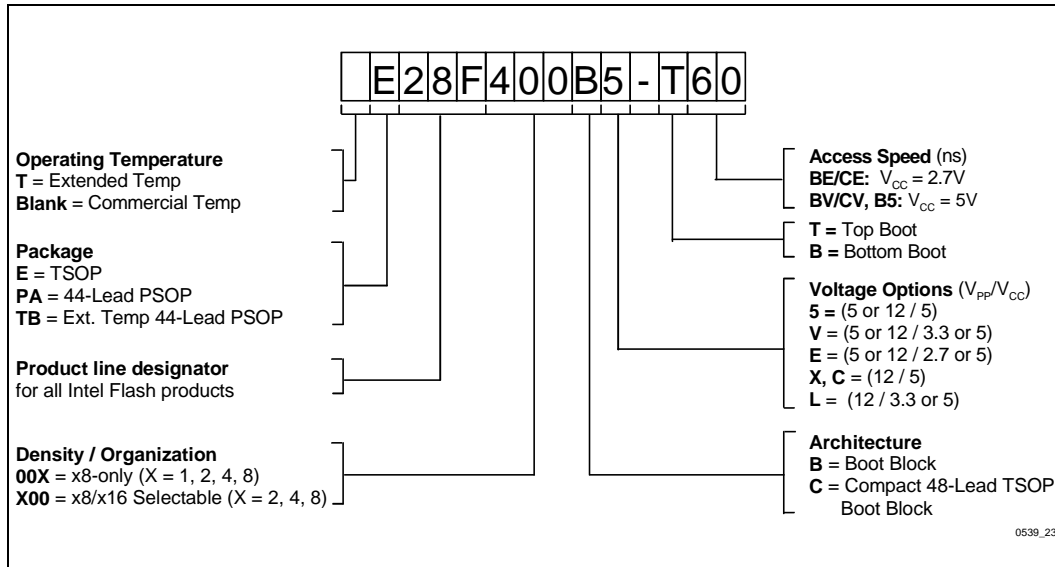

Figure 10. Decoding the Product Names



APPENDIX B ADDITIONAL INFORMATION

Order Number	Document
290599	<i>Smart 5 Boot Block Flash Memory Family 2, 4, 8 Mbit</i>
290531	<i>2-Mbit (128K x 16, 256K x 8) SmartVoltage Boot Block Flash Memory Family Datasheet</i>
290530	<i>4-Mbit (256K x 16, 512K x 8) SmartVoltage Boot Block Flash Memory Family Datasheet</i>
290539	<i>8-Mbit (512K x 16, 1024K x 8) SmartVoltage Boot Block Flash Memory Family Datasheet</i>
290578	<i>28F002BC 2-Mbit (256K x 8) Boot Block Flash Memory Datasheet</i>
290448	<i>2-Mbit (128K x 16, 256K x 8) Boot Block Flash Memory Family Datasheet</i>
290449	<i>2-Mbit (128K x 16, 256K x 8) Low-Power Boot Block Flash Memory Family Datasheet</i>
290451	<i>4-Mbit (256K X 16, 512K X 8) Boot Block Flash Memory Family Datasheet</i>
290450	<i>4-Mbit (256K X 16, 512K X 8) Boot Block Flash Memory Family Datasheet</i>
292164	<i>AP-611 Boot Block Compatability: 2/4 Mbit BX/BL with 2/4/8-Mbit BV</i>
292194	<i>AB-65 Migrating SmartVoltage Boot Block Designs to Smart 5</i>

NOTE:

1. Please call the Intel Literature Center at (800) 548-4725 to request Intel documentation. International customers should contact their local Intel or distribution sales office.
2. Visit Intel's World Wide Web home page at <http://www.Intel.com> for technical documentation and tools.

